

**CRANE**<sup>®</sup>

Energy Flow Solutions

# Center Line Resilient Seated Butterfly Valves





## Center Line Resilient Seated Butterfly Valves Product Features

- Suitable for both gaseous and liquid service
- Positive shut-off bi-directionally
- PTFE bushing standard
- Locking handle standard (2"-12")
- End of line service standard on lug style
- Ease of automation
- Field repairable 2"-12" phenolic backed seat\*  
14"-30" aluminum backed seat
- Complete size range: 2"-48"

Center Line has been a market leader in quarter-turn valves for more than 40 years, and we have earned a reputation as a supplier of superior valves at competitive prices. Our goal is to exceed industry requirements and customer expectations.

We are committed to offering products that meet a wide range of applications and requirements. We continually improve our product line by introducing new products and enhancing existing designs, providing our customers with the best products on the market.

Our complete line of resilient seated butterfly valves provides you with the reliability you need, backed by the assurance that comes with using valves designed and produced in company-owned manufacturing facilities.

## Typical Applications

- HVAC
- Chemical/ Petrochemical Processing
- Food and Beverage
- Power and Utilities
- Pulp and Paper

NOTE: In keeping with our policy of continuing improvement, we reserve the right to institute changes in design, material, dimensions, or specifications without notice and without incurring any obligation to make such changes and modifications on product previously or subsequently sold.

\*2-12" low temperature Viton® has aluminum backed seats.

Viton® is a registered trademark of DuPont Performance Elastomers.

# Resilient Seated Butterfly Valves



## Series 200 – 225 – 250

Quality is designed into Series 200, 225, and 250 butterfly valves from Center Line. These valves feature a phenolic backed or aluminum backed cartridge seat and precision-machined parts to assure years of dependable operation.

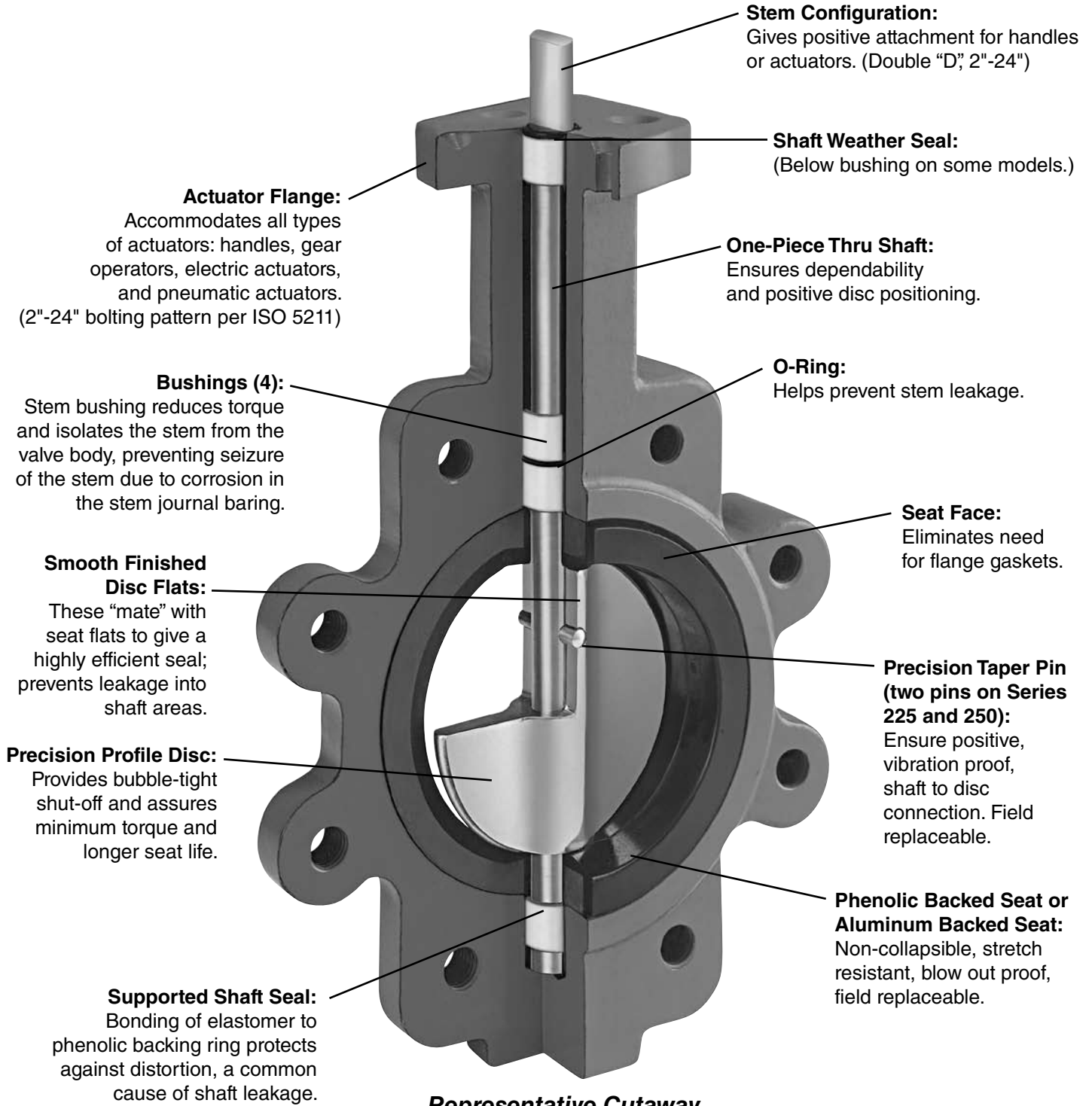



# Resilient Seated Butterfly Valves

## Series 200

- Available in sizes 2" to 48".
- Available in Wafer or Lug style body (2" to 30").
- Double flange available 28" to 48" valves.
- Wafer body features four alignment holes.
- Pressure ratings for tight shut-off at temperatures up to the maximum limit of the seat material:
  - 2" to 12" — 200 psi, 125 psi for PTFE/Buna seat.
  - 14" to 48" — 150 psi.
- Ideal for on-off or throttling services.
- Available with handles (2" to 12"), manual gear operators (2" to 48"), and electric or pneumatic actuators (2" to 48").
- Refer to Crane automation bulletin for details of pneumatic and electric actuators.
- Designed to comply with MSS SP-67.
- Compatible with ASME B16.1 and ASME B16.5 flanges.
- Valves 2" to 20" meet the intent and have passed the AWWA C-504-87 Section 5 proof of design tests.
- Type approval certification from ABS & USCG Category A for marine applications (2" to 48").
- Bi-directional dead-end capability to 200 psi (2" to 12") and 150 psi (14" to 24") is standard on lug valves.
- Operators mounted perpendicular to pipe.
- For bolting information, consult the Center Line Installation and Maintenance Manual.
- Vacuum Service Rating: zero leakage at 24" of mercury.
- Commercial cleaning available for Oxygen level 2.
- CE/PED Certification available for sizes 2" to 24".

### Valve Seating Torques (In-Lbs.) 2" to 30"

Valve Size	Standard Disc Differential Pressure								Undercut Diff. Press.	
	50 PSI ΔP Bushing		100 PSI ΔP Bushing		150 PSI ΔP Bushing		200 PSI ΔP Bushing		75 PSI ΔP Bushing	
	Bronze	PTFE	Bronze	PTFE	Bronze	PTFE	Bronze	PTFE	Bronze	PTFE
2"	106	100	117	106	129	111	140	117	-	-
2 ½"	152	150	166	163	181	176	195	189	-	-
3"	213	207	230	220	248	232	265	244	-	-
4"	321	290	386	323	450	357	515	390	-	-
5"	481	423	598	481	715	540	832	598	-	-
6"	692	599	878	691	1,063	783	1,248	875	-	-
8"	1,326	1,060	1,716	1,183	2,106	1,307	2,496	1,430	1,124	819
10"	2,239	1,671	3,010	1,872	3,780	2,074	4,550	2,275	1,363	909
12"	3,959	2,568	4,953	2,795	5,948	3,023	6,942	3,250	2,457	1,445
14"	4,881	2,640	6,226	3,070	7,570	3,500	-	-	4,400	2,300
16"	7,020	4,260	8,580	4,880	10,140	5,500	-	-	5,900	3,600
18"	10,105	6,287	12,202	7,243	14,300	8,200	-	-	8,300	5,500
20"	13,923	8,360	16,582	9,180	19,240	10,000	-	-	11,100	6,700
24"	23,617	15,427	26,953	16,813	30,290	18,200	-	-	17,300	12,100
30"	39,721	27,313	43,391	29,407	47,060	31,500	-	-	27,300	21,100

### Valve Seating Torques (In-Lbs.) 28" to 48" Double Flanged

Valve Size	Standard Disc Differential Pressure		
	50 PSI Wet	100 PSI Wet	150 PSI Wet
28"	23,718	26,639	28,957
30"	28,320	30,860	33,338
32"	32,418	35,073	38,126
36"	40,622	43,480	46,524
40"	68,924	74,048	78,995
42"	69,747	74,632	79,862
48"	96,598	103,837	111,112

All torques shown in these charts were derived from test data using water at 60°F. For torques using dry gases, multiply these numbers by 2.0. For torques involving other media, please consult the factory.

There is no safety factor included in the numbers shown on these charts. For actuator sizing, Crane recommends that these values be multiplied by 1.2 for single valve applications, or 2.0 for 3-way ("tee") applications.

For PTFE/Buna seats multiply the numbers shown by 2.0.

Under certain conditions, hydrodynamic torque can meet or exceed seating and unseating torques. When designing valve systems, hydrodynamic torque must be considered to help assure correct selection for the application.

# Resilient Seated Butterfly Valves



## Series 200

### Seat Temperature Ratings

Material	Temperature Ratings °F
Buna-N	+10 to 180
Abrasive Resistant Buna-N	+10 to 180
Neoprene	+20 to 200
EPDM (2" - 16")	-30 to 275
EPDM (18" & Above)	-30 to 225
EPDM, Food Grade (2" - 12")	-30 to 225
Viton®	+10 to 275
High Temp. Viton®	+10 to 400
PTFE over Buna-N (125 psi, 2" - 12")	+40 to 250

Although elastomers have an effective operating temperature range, when used in valves, these ranges may have to be modified. The temperature ranges shown in the table have been adjusted accordingly.

**For Low Temperature:** While the seat materials selected for use in Center Line butterfly valves are capable of withstanding lower temperatures without damage, the durometer of the elastomer is changed. This “hardening” of the seat may increase the operating torque beyond the structural limits of the stem and/or the disc to stem configuration.

**For High Temperature:** When using High Temperature Viton®, the operating pressure of the valve is reduced above 275°F.

**Field Replacement:** Replacing seats in sizes 14" and above requires factory service.

### C<sub>v</sub> Values – Valve Sizing Coefficients (US-GPM @ 1ΔP) 2" to 48"

Size	10°	20°	30°	40°	50°	60°	70°	80°	90°
2"	0.06	3	7	15	27	44	70	105	115
2 ½"	0.10	6	12	25	45	75	119	178	196
3"	0.20	9	18	39	70	116	183	275	302
4"	0.30	17	36	78	139	230	364	546	600
5"	0.50	29	61	133	237	392	620	930	1022
6"	0.80	45	95	205	366	605	958	1437	1579
8"	2	89	188	408	727	1202	1903	2854	3136
10"	3	151	320	694	1237	2047	3240	4859	5340
12"	4	234	495	1072	1911	3162	5005	7507	8250
14"	6	338	715	1549	2761	4568	7230	10844	11917
16"	8	464	983	2130	3797	6282	9942	14913	16388
18"	11	615	1302	2822	5028	8320	13168	19752	21705
20"	14	791	1647	3628	6465	10698	16931	25396	27908
24"	22	1222	2587	5605	9989	16528	26157	39236	43116
28"	36	1813	3639	6636	10000	14949	22769	34898	49500
30"	37	2080	4406	9546	17010	28147	44545	66818	73426
32"	45	2387	4791	8736	13788	20613	31395	48117	38250
36"	260	3050	6730	12740	20220	32500	52500	79600	87500
40"	84	4183	8395	15307	24159	36166	55084	84425	119750
42"	350	4095	9040	17108	27150	43640	70500	106890	117500
48"	455	5365	11840	22400	30600	51200	92300	140000	154000

## Series 200

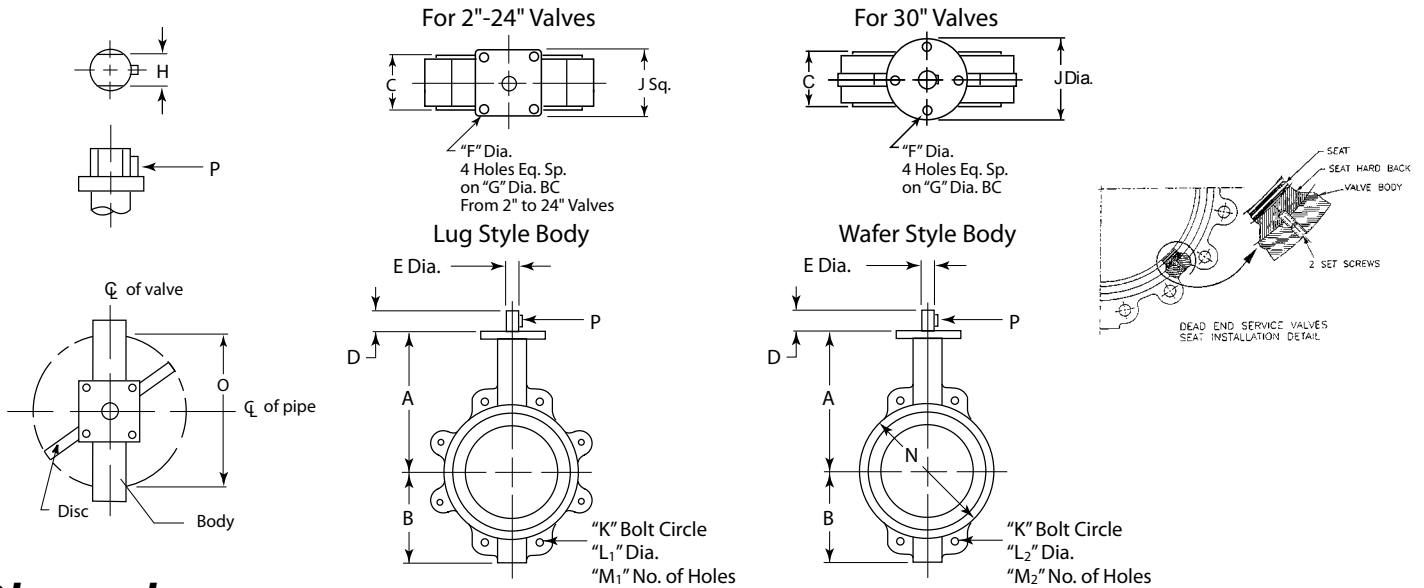

### Dimensions 2" - 30" Wafer & Lug

For installation and maintenance instructions, please refer to the IOM manual available at [www.cranevalvevit.com](http://www.cranevalvevit.com)

Inches / mm	A	B	C	D	E	F	G	H	J	K	L <sub>1</sub>	L <sub>2</sub>	M <sub>1</sub>	M <sub>2</sub>	N	O	P
2"	6 3/16	3 3/16	1 1/8	1 1/4	1/2	3/8	2.76	0.39	2 3/4	4 3/4	5/8-11	1 1/16	4	4	4	1.26	Woodruff #3
50	161.93	80.96	47.63	31.75	12.70	9.53	70	10	69.85	120.65		17.46			101.60	32.0	
2 1/2"	6 7/8	3 1/2	2	1 1/4	1/2	3/8	2.76	0.39	2 3/4	5 1/2	5/8-11	1 1/16	4	4	4 3/4	1.83	Woodruff #3
65	174.63	88.90	50.80	31.75	12.70	9.53	70	10	69.85	139.70		17.46			120.65	46.5	
3"	7 1/8	3 3/4	2	1 1/4	1/2	3/8	2.76	0.39	2 3/4	6	5/8-11	1 1/16	4	4	5	2.54	Woodruff #3
80	180.98	95.25	50.80	31.75	12.70	9.53	70	10	69.85	152.40		17.46			127.00	64.5	
4"	7 7/8	4 1/2	2 1/8	1 1/4	5/8	3/8	2.76	0.47	2 3/4	7 1/2	5/8-11	1 1/16	8	4	6 1/4	3.54	Woodruff #9
100	200.03	114.30	53.98	31.75	15.88	9.53	70	12	69.85	190.50		17.46			158.75	89.9	
5"	8 3/8	5	2 3/8	1 1/4	3/4	3/8	2.76	0.55	2 3/4	8 1/2	3/4-10	1 3/16	8	4	7 1/2	4.36	Woodruff #9
125	212.73	127.00	60.33	31.75	19.05	9.53	70	14	69.85	215.90		20.64			190.50	110.7	
6"	8 7/8	5 1/2	2 3/8	1 1/4	3/4	3/8	2.76	0.55	2 3/4	9 1/2	3/4-10	1 3/16	8	4	8 3/8	5.72	Woodruff #9
150	225.43	139.70	60.33	31.75	19.05	9.53	70	14	69.85	241.30		20.64			212.73	145.3	
8"	10 1/4	6 7/8	2 1/2	1 3/4	7/8	7/16	4.02	0.67	3 3/4	11 3/4	3/4-10	1 3/16	8	4	10 5/8	7.6	Woodruff #9
200	260.35	174.63	63.50	44.45	22.23	11.11	102	17	95.33	298.45		20.64			269.88	193.0	
10"	11 1/2	8	2 3/4	1 3/4	1 1/8	7/16	4.02	0.87	3 3/4	14 1/4	1/2-9	1 3/16	12	4	12 5/8	9.5	Woodruff #15
250	292.10	203.20	69.85	44.45	28.58	11.11	102	22	95.33	361.95		23.81			327.03	241.3	
12"	13 1/4	9 5/8	3 1/8	1 3/4	1 1/4	7/16	4.02	0.95	3 3/4	17	1/2-9	1 3/16	12	4	15 5/8	11.45	Woodruff #15
300	336.55	244.48	79.38	44.45	31.75	11.11	102	24	95.33	431.80		23.81			403.23	290.8	
14"	14 1/2	10 1/2	3 1/8	1 3/4	1 1/4	7/16	4.02	0.95	3 3/4	18 3/4	1-8	1 1/16	12	4	17 5/8	12.78	Woodruff #15
350	368.30	266.70	79.38	44.45	31.75	11.11	102	24	95.33	476.25		26.99			434.98	324.6	
16"	15 3/4	12 1/8	3 1/2	2	1 3/16	7/8	6.50	1.06	6 1/2	21 1/4	1-8	1 1/16	16	4	19 1/4	14.97	5/16" Sq. x 1 3/4"
400	400.05	327.02	88.90	50.80	33.34	22.23	165	27	165.10	539.75		26.99			488.95	380.2	
18"	16 3/8	13 3/8	4 1/4	2	1 1/2	7/8	6.50	1.06	6 1/2	22 3/4	1 1/8-7	1 1/4	16	4	21 1/4	16.83	3/8" Sq. x 1 1/2"
450	422.28	346.08	107.95	50.80	38.10	22.23	165	27	165.10	577.85		31.75			539.75	427.5	
20"	18 1/8	15 1/8	5 3/8	2 3/4	1 5/8	7/8	6.50	1.26	6 1/2	25	1 1/8-7	1 1/4	20	4	23 3/8	18.67	3/8" Sq. x 1 3/4"
500	479.43	384.18	136.53	63.50	41.28	22.23	165	32	165.10	635.00		31.75			650.88	474.2	
24"	22 1/8	18 3/8	6 1/8	2 3/4	2	7/8	6.50	1.42	6 1/2	29 1/2	1 1/4-7	1 3/8	20	4	27 5/8	22.62	1/2" Sq. x 2 1/4"
600	561.98	466.73	155.58	69.85	50.80	22.23	165	36	165.10	749.30		34.93			708.03	574.5	
30"	25 1/2	24 3/4	6 3/4	3 1/4	2 1/2	7/8	8 1/2	N/A	11 1/4	36	1 1/4-7	1 1/4	28	4	34 3/8	28.6	5/8" Sq. x 2 5/8"
750	647.70	628.65	171.45	82.55	63.50	22.23	215.90		285.75	914.40		31.75			873.13	726.4	

L<sub>1</sub> and M<sub>1</sub> refer to Lug style valves, L<sub>2</sub> and M<sub>2</sub> refer to Wafer Style. "C" dimension is listed with elastomer in the relaxed condition. Approximately 1/8" total compression is required for proper sealing with pipe flanges. Valves are designed for installation between ASME B16.1 Class 125 (Iron) and B16.5 Class 150 (Steel) flanges. Gaskets are not needed, and should not be used since the seat face seals against the mating flange. If the valve is to be installed in between any other flanges, consult your Center Line agent or the factory for additional information. Center Line recommends that a blind flange be used on end of line applications.

"O" dimension is the valve clearance dimension.

# Resilient Seated Butterfly Valves



## Series 200

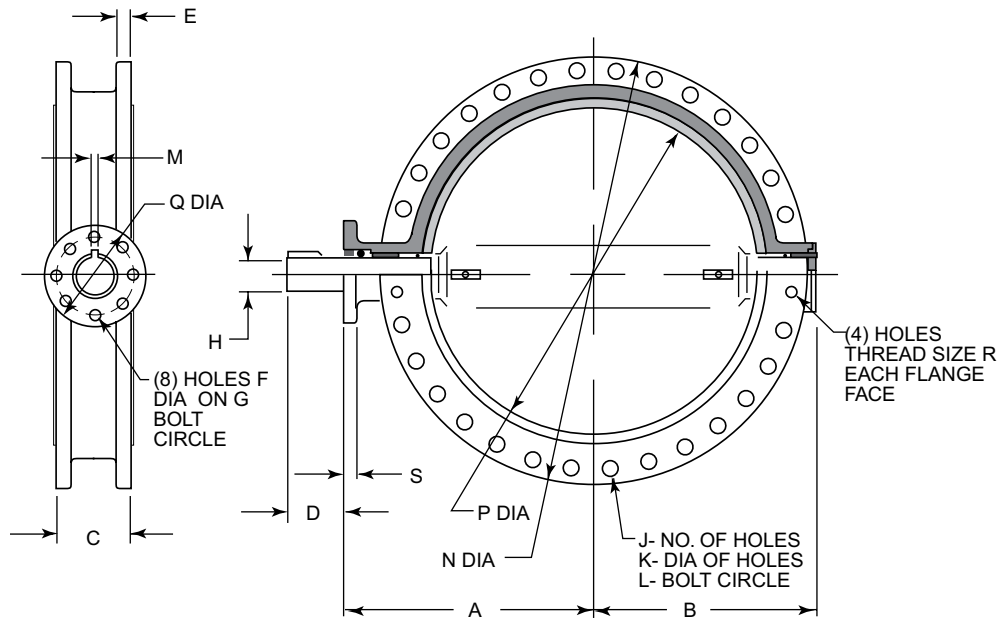

### \*Dimensions 28" - 48" Double Flanged

For installation and maintenance instructions, please refer to the IOM manual available at [www.cranevalvelit.com](http://www.cranevalvelit.com)

	A	B	C	D	E	F	G	H	J	K	L	M	N	P	Q	R	S
28 in	24.6	20.5	6.6	3.7	2.2	0.7	10	2.5	24	1.4	34	0.7 Sq.	36.6	27.8	11.8	1.25 - 7	1.3
mm	626	521	165	95	54	18	254	63.4	24	35	863.4	18 Sq.	930	695	300	-	33
30 in	26.0	21.8	6.7	3.7	2.2	0.7	10	2.5	24	1.4	36	0.7 Sq.	39.4	29.8	11.8	1.25 - 7	1.3
mm	660	554	167	95	54	18	254	63.4	24	35	914.4	18 Sq.	984	744	300	-	33
32 in	26.2	23.3	7.6	3.7	2.4	0.7	10	2.5	24	1.6	39.5	0.7 Sq.	42.4	31.8	11.8	1.5 - 6	1.3
mm	666	591	190	95	60.3	18	254	63.4	24	41.3	978	18 Sq.	1060	795	300	-	33
36 in	28.4	25.6	8.1	5.1	2.4	0.7	10	3	28	1.6	42.75	0.8 Sq.	47	34.0	11.8	1.5 - 6	1.3
mm	722	650	203	130	60.3	18	254	75	28	41.3	1086	20 Sq.	1169	864.7	300	-	33
40 in	31.7	28.1	8.7	5.1	2.4	0.7	10	3.3	32	1.6	47.25	0.9 Sq.	51.6	38.6	11.8	1.5 - 6	1.5
mm	806	713	218	130	60.3	18	254	85	32	41.3	1200	22 Sq.	1289	965	300	-	38
42 in	34.1	30.3	10	5.9	2.6	0.7	10	3.3	32	1.6	49.5	0.9 Sq.	53	40.5	11.8	1.5 - 6	1.4
mm	865	770	251	150	66	18	254	85	32	41.3	1257	22 Sq.	1346	1030	300	-	35
48 in	36.9	33.7	10.9	5.9	2.8	0.9	11.7	4.1	40	1.6	56	1.1 Sq.	59.5	45.7	13.8	1.5 - 6	1.5
mm	938	855	276.4	150	70	22	298	105	40	41.3	1422	28 Sq.	1511	1160	350	-	38

\* Please note that dimensions apply to standard product only.

### Weights 2" - 48" - lbs (kg)

	2"	2 1/2"	3"	4"	5"	6"	8"	10"	12"	14"	16"	18"	20"	24"	28"	30"	32"	36"	40"	42"	48"
Wafer	6 (2.7)	7 (3.2)	10 (4.5)	13 (5.9)	18 (8.2)	20 (9.1)	32 (14.5)	42 (19.1)	70 (31.7)	95 (43.1)	117 (53.1)	165 (74.8)	275 (124.7)	440 (199.6)	-	740 (335.7)	-	-	-	-	-
Lug	7 (3.2)	8 (3.6)	14 (6.4)	26 (11.8)	28 (12.7)	31 (14.1)	49 (22.2)	72 (32.7)	105 (47.6)	155 (70.3)	195 (88.5)	230 (104.3)	396 (179.6)	610 (276.7)	-	1050 (476.3)	-	-	-	-	-
Flanged	-	-	-	-	-	-	-	-	-	-	-	-	-	-	1173 (533)	1173 (533)	1525 (693)	1949 (886)	2141 (973)	2495 (1134)	3711 (1687)

Note: Technical data subject to change without notice.

## Series 200

Sizes 2"-30"

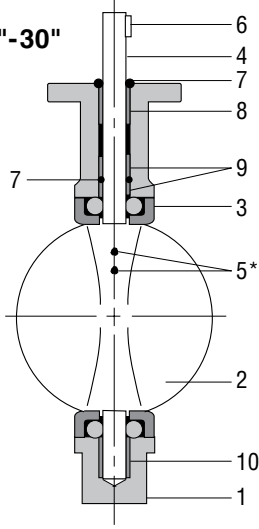

\*Quantity of 3 pins required for 30" lug or wafer style valves.

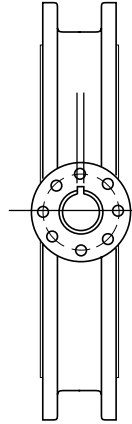

Sizes 28"-48"

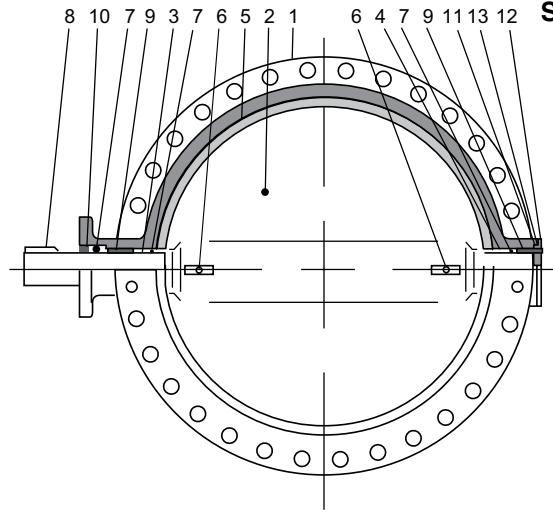

### Bill of Materials 2" - 30"

Item	Description	Materials	Optional Materials
1	Body	Cast Iron (A126-GR B)	Ductile Iron (A536 65-45-12), (A395 60-40-18)
2	Disc	Ductile Iron† (A536 65-45-12)	Aluminum Bronze (B148-C954), 316 SS (A351-CF8M), Monel® (A494-M30C)
3	Seat	Buna-N or EPDM	Neoprene, Viton®, PTFE, FDA, Abrasion Resistant
4	Shaft	416 Stainless Steel (A582-416)	316 Stainless Steel (A276/A479-316), Monel® (B164-K400 CL-B), 17-4PH (A564-630/1150)
5	Taper Pins	416 Stainless Steel (A582-416)	316 Stainless Steel (A276/A479-316), Monel® (B164-K400 CL-B), 17-4PH (A564-630/1150)
6	Key	Carbon Steel	No Option Available
7	O-Ring	Buna-N	No Option Available
8	Bushing	PTFE	Luberized Bronze
9	Bushing	PTFE	Luberized Bronze
10	Bushing	PTFE	Luberized Bronze

†ENP plated for 2"-12" valves

### Bill of Materials 28" - 48"

Item	Description	Materials	Optional Materials
1	Body	Ductile Iron (A536 65-45-12)	Ductile Iron (A395 60-40-18)
2	Disc	Ductile Iron (A536 65-45-12)	Aluminum Bronze (B148-C954), 316 SS (A351-CF8M)
3	Upper Shaft	416 Stainless Steel (A582-416)	316 SS (std. w/ 316 SS disc) (A276/A479-316)
4	Lower Shaft	416 Stainless Steel (A582-416)	316 SS (std. w/ 316 SS disc) (A276/A479-316)
5	Seat	Buna-N or EPDM	Viton®
6	Taper Pin	416 Stainless Steel (A582-416)	316 Stainless Steel (A276/A479-316)
7	O-Ring	Buna-N	No Option Available
8	Key	Carbon Steel	No Option Available
9	Bushing	TFE	Luberized Bronze
10	Bushing	TFE	Luberized Bronze
11	Thrust Washer	TFE	Luberized Bronze
12	End Plate	Ductile	No Option Available
13	O-Ring	Buna-N	No Option Available

Monel® is a registered trademark of Special Metals Corporation.



# Resilient Seated Butterfly Valves



## Series 225-250

- Available in sizes 2" to 24".
- Pressure Rating: 285 psi at 100°F. Pressure/Temperature rating above 100°F with downstream flange installed. Available option: Bi-directional dead-end service capability without downstream flange to 200 psi (2" to 12") and 150 psi (14" to 24").
- Available in Wafer or Lug style body.
- Wafer body features four alignment holes.
- Available in ASME Class 300 Lug Body bolt pattern (2" to 12"). Series 225 only.
- Ideal for on-off or throttling services.
- Available with handles (2" to 6"), manual gear operators, electric actuators and pneumatic actuators (2" to 24").
- Refer to Crane automation bulletin for details of pneumatic and electric actuators.
- Compatible with ASME B16.1 Class 125 (Iron) and ASME B16.5 Class 150 (Steel) flanges or optional Class 300 (Steel) Lug only.
- Valves 14" and larger are rated at a maximum 150 psi when a companion flange is not used in dead end service.
- For bolting information, consult the Center Line Installation and Maintenance Manual.
- Vacuum Service Rating: zero leakage at 24" of mercury.
- Commercial cleaning available for Oxygen level 2.
- Type approval certification from ABS for Marine applications (2" to 24").
- CE/PED Certification available for sizes 2" to 24".

### Valve Seating Torques (In-Lbs.)

Valve Size	Standard Disc Differential Pressure				
	50 PSI	100 PSI	150 PSI	200 PSI	285 PSI
2"	136	142	148	154	164
2 1/2"	152	160	168	176	189
3"	224	229	234	239	247
4"	380	392	404	416	436
5"	451	477	503	529	572
6"	875	946	1016	1087	1206
8"	1476	1559	1642	1726	1867
10"	2451	2613	2775	2937	3213
12"	3900	4111	4323	4534	4893
14"	5189	5467	5744	6022	6494
16"	10,985	11,569	12,154	12,738	13,732
18"	13,946	14,688	15,431	16,173	17,434
20"	14,695	15,478	16,260	17,043	18,373
24"	29,738	31,321	32,903	34,486	37,176

All torques shown on the chart were derived from test data using water at 60°F. For torques using dry gases, multiply these numbers by 2.0. For torques involving other media, please consult the factory.

There is no safety factor included in the numbers shown on this chart. For actuator sizing, Center Line recommends that these values be multiplied by 1.2 for single valve applications, or 2.0 for 3-way ("tee") applications.

For PTFE seats multiply the numbers shown on this chart by 2.0.

Under certain conditions, hydrodynamic torque can meet or exceed seating and unseating torques. When designing valve systems, hydrodynamic torque must be considered to help assure correct selection for the application.

### Seat Temperature Ratings

Material	Temperature Rating °F
Buna-N	+10 to 180
EPDM (2"-16")	-30 to 275
EPDM (18"-24")	-30 to 225
Abrasive Resistant Buna-N	+10 to 180
Neoprene	+20 to 200
Viton®	+10 to 275
High Temperature Viton®	+10 to 400
PTFE (Series 250 only)	+40 to 250

Although elastomers have an effective operating temperature range, when used in valves, these ranges may have to be modified. The temperature ranges shown in the table have been adjusted accordingly.

**For Low Temperature:** While the seat materials selected for use in Center Line butterfly valves are capable of withstanding lower temperatures without damage, the durometer of the elastomer is changed. This "hardening" of the seat may increase the operating torque beyond the structural limits of the stem and/or the disc to stem configuration.

**For High Temperature:** When using High Temperature Viton®, the operating pressure of the valve is reduced above 275°F.

**Field Replacement:** Replacing seats in sizes 14" and above requires factory service.

### C<sub>v</sub> Values – Valve Sizing Coefficients (US-GPM @ 1ΔP)

Size	10°	20°	30°	40°	50°	60°	70°	80°	90°
2"	0.06	3	7	15	27	44	70	105	115
2 1/2"	0.10	6	12	25	45	75	119	178	196
3"	0.20	9	18	39	70	116	183	275	302
4"	0.30	17	36	78	139	230	364	546	600
5"	0.50	29	61	133	237	392	620	930	1022
6"	0.80	34	94	153	257	422	706	1154	1320
8"	2	56	154	251	422	693	1158	1892	2165
10"	3	87	238	385	654	1073	1794	2931	3353
12"	4	153	417	681	1145	1879	3142	5132	5827
14"	6	183	500	816	1372	2252	3765	6150	7037
16"	8	271	740	1208	2031	3333	5573	9104	10,416
18"	11	318	867	1417	2382	3909	6535	10,676	12,215
20"	14	415	1133	1851	3112	5107	8538	13,948	15,959
24"	22	543	1482	2421	4069	6678	11,165	18,240	20,869

## Series 225-250

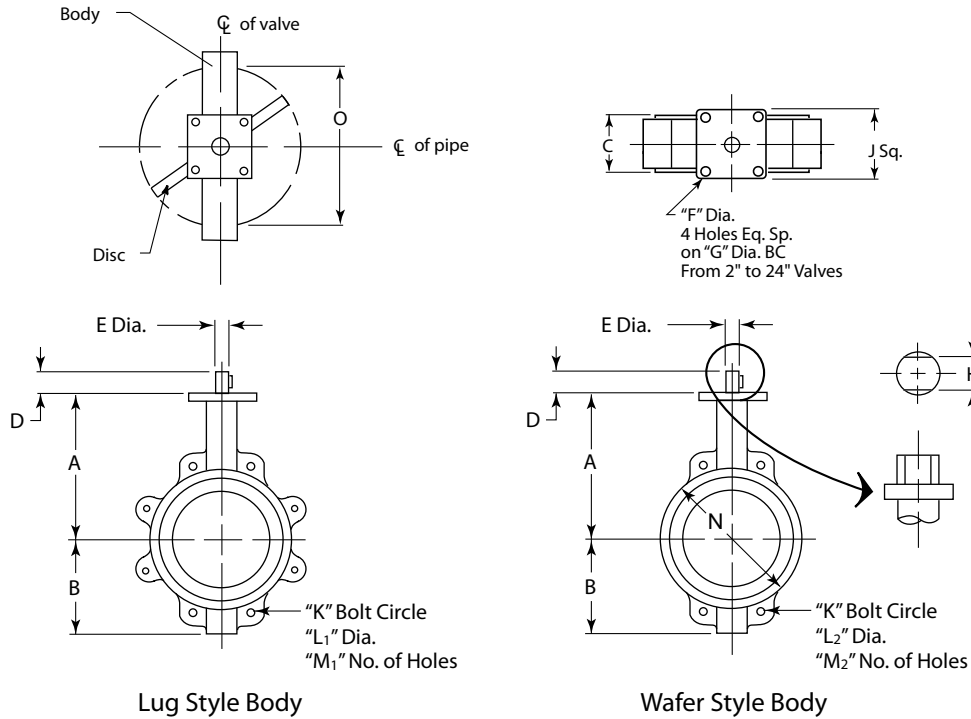

## Dimensions and Weights

For installation and maintenance instructions, please refer to the IOM manual available at [www.cranvalvelit.com](http://www.cranvalvelit.com)

Inches / mm	A	B	C	D	E	F	G	H	J	K	300# K	L <sub>1</sub>	300# L <sub>1</sub>	L <sub>2</sub>	M <sub>1</sub>	300# M <sub>1</sub>	M <sub>2</sub>	N	Wafer	Lug	300# Lug	O	
2"	6 3/8	3 3/16	1 7/8	1 1/4	1/2	3/8	2.76	0.39	2 3/4	4 3/4	5	5/8-11	5/8-11	1 1/16	4	4	4	4	6 lbs.	9 lbs.	9 lbs.	1.26	
50	161.93	80.96	47.63	31.75	12.70	9.53	70	10	69.85	120.65	127.00	17.46	17.46	17.46	4	4	4	101.60	2.72 kg	4.08 kg	4.08 kg	32.0	
2 1/2"	6 7/8	3 1/2	2	1 1/4	1/2	3/8	2.76	0.39	2 3/4	5 1/2	5 1/8	5/8-11	3/4-10	1 1/16	4	8	4	4	4 3/4	7 lbs.	13 lbs.	13 lbs.	1.83
65	174.63	88.90	50.80	31.75	12.70	9.53	70	10	69.85	139.70	149.23	17.46	17.46	17.46	4	8	4	120.65	3.18 kg	5.90 kg	5.90 kg	46.5	
3"	7 1/8	3 3/4	2	1 1/4	1/2	3/8	2.76	0.39	2 3/4	6	6 3/8	5/8-11	3/4-10	1 1/16	4	8	4	4	5	10 lbs.	14 lbs.	14 lbs.	2.54
80	180.98	95.25	50.80	31.75	12.70	9.53	70	10	69.85	152.40	168.28	17.46	17.46	17.46	4	8	4	127.00	4.54 kg	6.35 kg	6.35 kg	64.5	
4"	7 7/8	4 1/2	2 1/8	1 1/4	5/8	3/8	2.76	0.47	2 3/4	7 1/2	7 7/8	5/8-11	3/4-10	1 1/16	8	8	4	6 1/4	13 lbs.	19 lbs.	24 lbs.	3.54	
100	200.03	114.30	53.98	31.75	15.88	9.53	70	12	69.85	190.50	200.03	17.46	17.46	17.46	8	8	4	158.75	5.90 kg	8.62 kg	10.89 kg	89.9	
5"	8 3/8	5	2 3/8	1 1/4	3/4	3/8	2.76	0.55	2 3/4	8 1/2	9 1/4	3/4-10	3/4-10	1 1/16	8	8	4	7 1/2	18 lbs.	22 lbs.	29 lbs.	4.36	
125	212.73	127.00	60.33	31.75	19.05	9.53	70	14	69.85	215.90	234.95	20.64	20.64	20.64	8	8	4	190.50	8.16 kg	9.98 kg	13.15 kg	110.7	
6"	8 7/8	5 1/2	2 3/8	1 1/4	3/4	3/8	2.76	0.55	2 3/4	9 1/2	10 3/8	3/4-10	3/4-10	1 1/16	8	12	4	8 3/8	21 lbs.	31 lbs.	38 lbs.	5.74	
150	225.43	139.70	60.33	31.75	19.05	9.53	70	17	69.85	241.30	269.88	20.64	20.64	20.64	8	12	4	212.73	9.53 kg	14.06 kg	17.24 kg	145.8	
8"	10 1/4	6 7/8	2 1/2	1 3/4	7/8	7/16	4.02	0.67	3 3/4	11 3/4	13	3/4-10	7/8-9	1 1/16	8	12	4	10 7/8	34 lbs.	49 lbs.	67 lbs.	7.63	
200	260.35	174.63	63.50	44.45	22.23	11.11	102	17	95.33	298.45	330.20	20.64	20.64	20.64	8	12	4	269.88	15.42 kg	22.23 kg	30.39 kg	193.8	
10"	11 1/2	8	2 3/4	1 3/4	1 1/8	7/16	4.02	0.87	3 3/4	14 1/4	15 1/4	7/8-9	1-8	1 1/16	12	16	4	12 1/8	45 lbs.	62 lbs.	100 lbs.	9.54	
250	292.10	203.20	69.85	44.45	28.58	11.11	102	22	95.33	361.95	387.35	23.81	23.81	23.81	12	16	4	327.03	20.41 kg	28.12 kg	45.36 kg	242.3	
12"	13 1/4	9 5/8	3 1/8	1 3/4	1 1/4	7/16	4.02	0.95	3 3/4	17	17 3/4	7/8-9	1 1/8-7	1 1/16	12	16	4	15 7/8	74 lbs.	105 lbs.	144 lbs.	11.5	
300	336.55	244.48	79.38	44.45	31.75	11.11	102	24	95.33	431.80	450.85	26.99	26.99	26.99	12	16	4	403.23	33.57 kg	47.63 kg	65.32 kg	292.1	
14"	14 1/2	11	3 1/8	1 3/4	1 1/4	7/16	4.02	0.95	3 3/4	18 3/4	22 1/4	1-8	-	1 1/16	12	-	4	17 5/8	109 lbs.	178 lbs.	-	12.81	
350	368.30	279.00	79.38	44.45	31.75	11.11	102	24	95.33	476.25	-	-	-	26.99	12	-	4	447.68	49.44 kg	80.74 kg	-	325.4	
16"	15 3/4	12	3 1/2	2	1 5/16	7/8	6.50	1.06	6 1/2	21 1/4	-	1-8	-	1 1/16	16	-	4	20 1/4	135 lbs.	224 lbs.	-	15	
400	400.05	305.00	88.90	50.80	33.34	22.23	165	27	165.10	539.75	-	-	-	26.99	16	-	4	514.35	61.24 kg	101.60 kg	-	381.0	
18"	16 3/8	13 1/8	4 1/4	2	1 3/8	7/8	6.50	1.26	6 1/2	22 3/4	-	1 1/8-7	-	1 1/16	16	-	4	21 1/2	190 lbs.	265 lbs.	-	16.87	
450	422.28	336.55	107.95	50.80	41.28	22.23	165	32	165.10	577.85	-	-	-	31.75	16	-	4	546.10	86.18 kg	120.20 kg	-	428.5	
20"	18 7/8	14 5/8	5 3/8	2 1/2	1 5/8	7/8	6.50	1.26	6 1/2	25	-	1 1/8-7	-	1 1/16	20	-	4	23 3/4	316 lbs.	455 lbs.	-	18.69	
500	479.43	371.48	136.53	63.50	41.28	22.23	165	32	165.10	635.00	-	-	-	31.75	20	-	4	603.25	143.34 kg	206.38 kg	-	474.7	
24"	22 1/8	18	6 1/8	2 3/4	3	7/8	6.50	2.36	6 1/2	29 1/2	-	1 1/4-7	-	1 1/16	20	-	4	27 7/8	506 lbs.	702 lbs.	-	22.57	
600	561.98	457.20	155.58	69.85	76.20	22.23	165	60	165.10	749.30	-	-	-	31.75	20	-	4	708.03	229.52 kg	318.42 kg	-	573.3	

# Resilient Seated Butterfly Valves



## Series 225-250

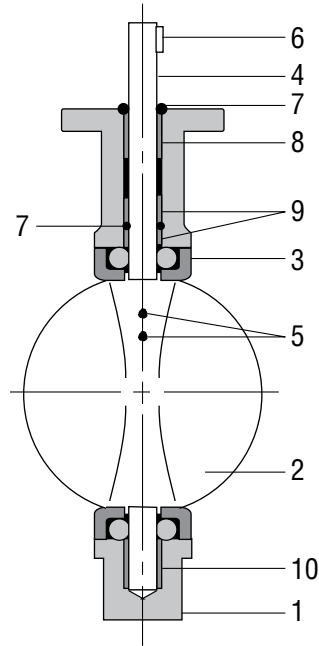

### Bill of Materials (Series 225)

Item	Description	Materials	Optional Materials
1	Body	Ductile Iron (A536 65-45-12)	Ductile Iron (A395 60-40-18)
2	Disc	Ductile Iron† (A536 65-45-12)	Aluminum Bronze (B148-C954), 316 SS (A351-CF8M), Monel® (A494-M30C)
3	Seat	Buna-N or EPDM	Neoprene, Abrasive Resistant Buna-N, Viton®, High Temperature Viton®
4	Shaft	416 Stainless Steel (A582-416)	2"-12": 17-4 PH (A564-630/1150), Monel® (B865-K500 CL-A)
5	Taper Pin	416 Stainless Steel (A582-416)	17-4 PH (A564-630/1150), Monel® (B865-K500 CL-A)
6	Key	Carbon Steel	No Option Available
7	O-Ring	Buna-N	No Option Available
8	Bushing	PTFE	No Option Available
9	Bushing	PTFE	No Option Available
10	Bushing	PTFE	No Option Available

†ENP plated for 2" - 12" valves

### Bill of Materials (Series 250)

Item	Description	Materials	Optional Materials
1	Body	Carbon Steel (A216 GR.WCB)	316SS (A351 GR.CF8M) Carbon Steel (A-216 GR.WCB Impact Tested)*
2	Disc	316 Stainless (A351-CF8M)	Aluminum Bronze (B148-C954), Monel® (A494-M30C)
3	Seat	Buna-N or EPDM	Neoprene, Abrasion Resistant Buna-N, Viton®, High Temperature Viton®, PTFE
4	Shaft	316 SS (A276/A479-316)	17-4 PH (A564-630/1150), Monel® (B865-K500 CL-A)
5	Taper Pin	316 SS (A276/A479-316)	17-4 PH (A564-630/1150), Monel® (B865-K500 CL-A)
6	Key	Carbon Steel	No Option Available
7	O-Ring	Buna-N	No Option Available
8, 9, 10	Bushing	PTFE	No Option Available

\* Center Line Series 250 Carbon Steel valves with CE marking are good to 0°F for non-impact tested bodies and -20°F for impact tested carbon steel bodies. Please refer to page 23 for the correct ordering code.

## Series 700

### Features and Benefits

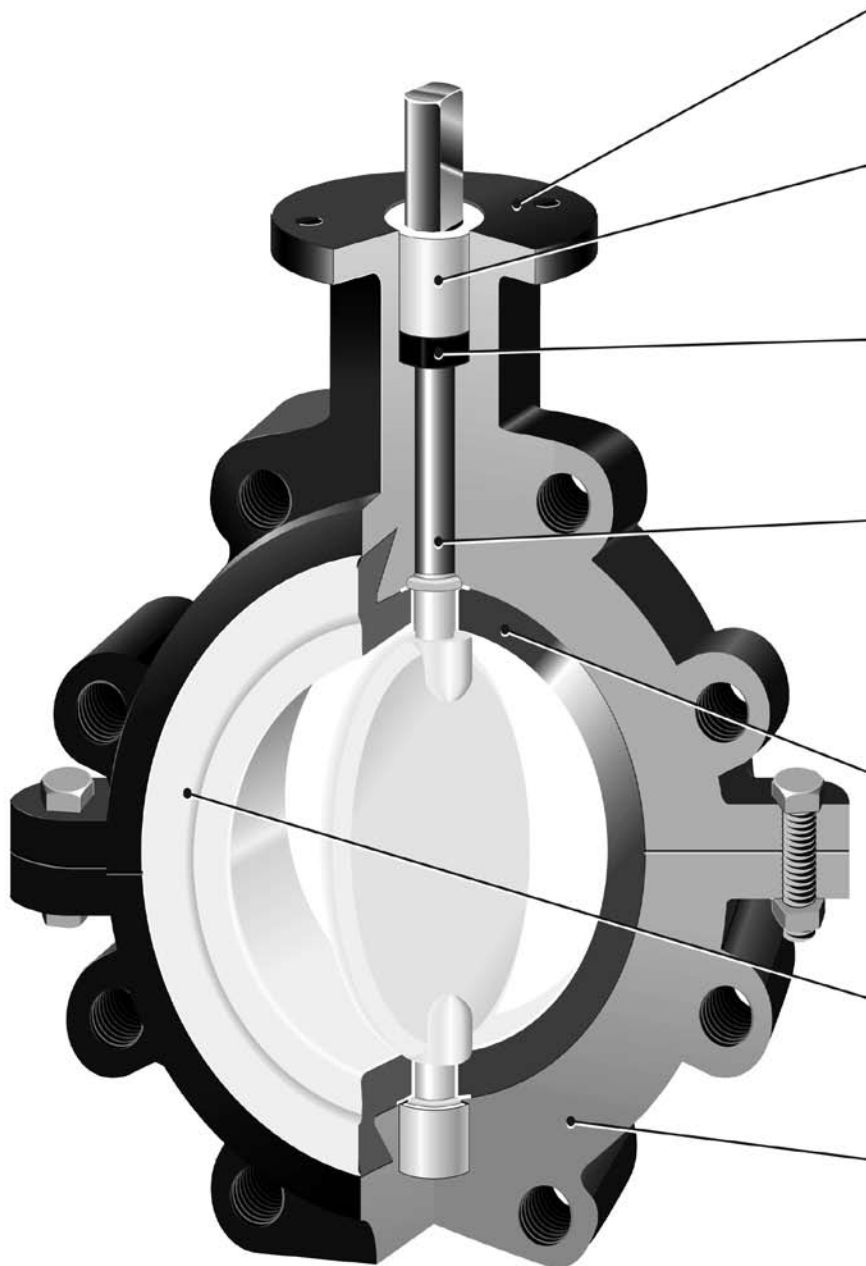

**Mounting Flange:**

Standard drilling accommodates 10-position handle kits, gear operators, or direct actuator mounting. ISO 5211 drilling template also available.

**Stem Bushings:**

Due to the unique design of the Center Line Series 700 valves, the ertalyte bushings absorb the radial thrust of gear operators and actuation to keep the disc/stem stable and centered.

**Weather Seal:**

EPDM, Buna-N, or Viton® stem seal protects media from external environment as well as ensures line media remains within the pressure boundaries of the valve.

**Disc/Stem:**

Standard disc is duplex stainless steel (255 stainless) which is corrosion resistant and stronger than 316 stainless. The disc and stem are one piece to minimize potential damage from over-torquing and line surges. Also available as Teflon®-encapsulated 255 SS.

**Seat:**

Center Line Series 700 standard liner is Buna-N. This liner comes with FDA approval in either black or white. It is also Abrasion Resistant. EPDM and Viton® are readily available. PTFE backed with EPDM or Viton® as well as other materials are also available.

**Seat Face:**

Liner extends away from the body of the valve to contact flange face. The compression of the seat allows for a tight seal against all standard flanges.

**Body:**

Standard material is Ductile Iron which is suitable for lug style class 150 ASME drilling patterns. Provides superior strength in wafer style. Stainless Steel 2-piece wafer or lug are also available.

Teflon is a registered trademark of E. I. du Pont de Nemours and Company or its affiliates.

# Resilient Seated Butterfly Valves



## Series 700

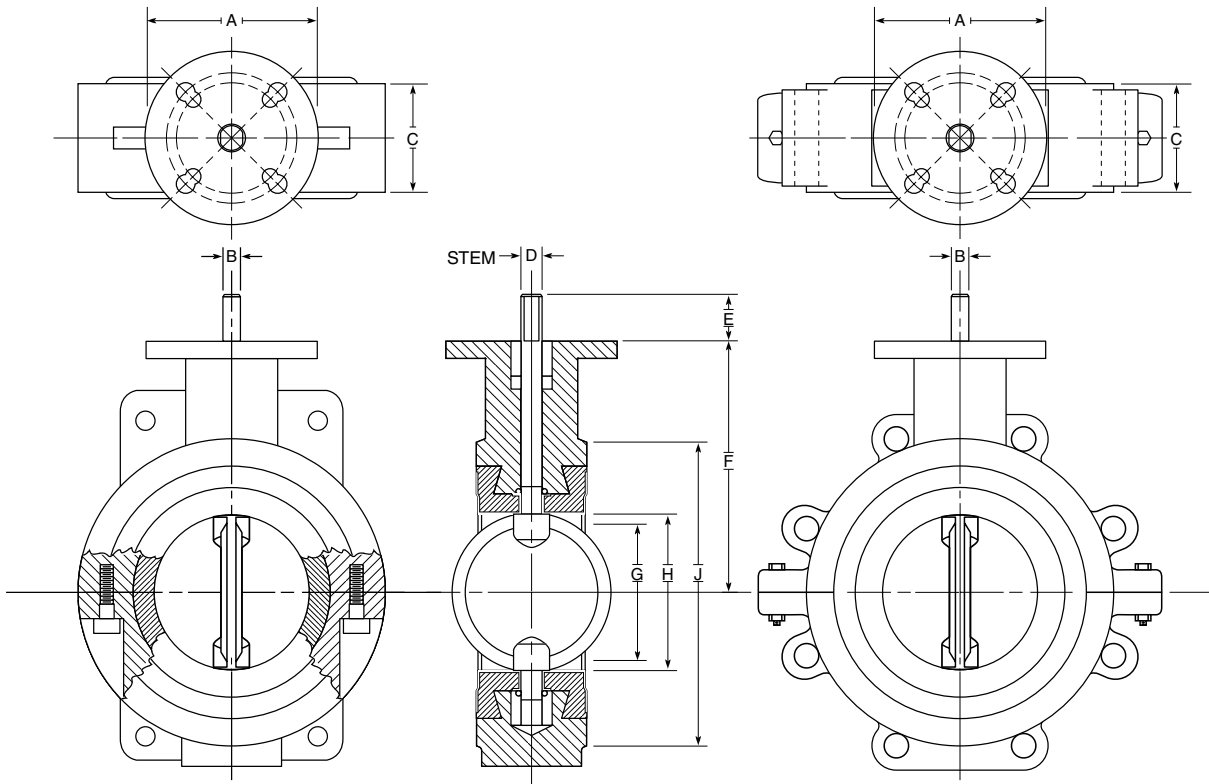

### Dimensions

For installation and maintenance instructions, please refer to the IOM manual available at [www.cranevalvelit.com](http://www.cranevalvelit.com)

	1	1.5	2	2.5	3	4	5	6	8	10	12
A	2.560	2.560	4.000	4.000	4.000	4.000	4.000	4.000	6.000	6.000	6.000
B	.250	.250	.375	.375	.375	.438	.500	.500	.625	—	—
C	1.125	1.188	1.625	1.750	1.750	2.000	2.125	2.125	2.500	2.500	3.000
D	.375	.375	.563	.563	.563	.625	.750	.750	.875	1.125	1.125
E	.750	.750	1.250	1.250	1.250	1.250	1.250	1.250	1.250	2.000	2.000
F	3.540	4.120	3.938	4.500	4.875	6.000	6.000	6.500	8.313	9.000	10.625
G	.625	1.438	1.375	2.063	2.563	3.625	4.750	5.500	7.500	9.594	11.563
H	1.188	1.750	2.000	2.500	3.000	4.000	5.000	5.750	7.750	9.750	11.750
J	2.437	3.218	4.125	4.825	5.250	6.750	7.625	8.625	10.812	13.375	16.188

"C" is installed width • "G" is min. Allowable inside dia. Of pipe or mating flange

1"-8" — "D" is stem connection dia.; "B" is flats • 10" - 12" — "D" is stem connection dia.; keyway is .250 x .250

### Top Plate Drilling Pattern

	1	1.5	2	2.5	3	4	5	6	8	10	12
No. Holes	N/A	N/A	4	4	4	4	4	4	4	4	4
Bolt Circle	—	—	3.250	3.250	3.250	3.250	3.250	3.250	5.000	5.000	5.000
Hole Dia.	—	—	.438	.438	.438	.438	.438	.438	.563	.563	.563

ISO	1	1.5	2	2.5	3	4	5	6	8	10	12
No. Holes	4	4	4	4	4	4	4	4	4	4	4
Bolt Circle	1.970	1.970	2.760	2.760	2.760	2.760	2.760	2.760	4.020	4.020	4.020
Hole Dia.	.281	.281	.375	.375	.375	.375	.375	.375	.406	.406	.406

Standard and ISO drilling come on each valve

Velocity limits - for on/off services

Fluids - 9 m/s (30 ft/sec) gases - 54 m/s (175 ft/sec)

### Expected Seat/Unseat Torque

in/lbs	1	1.5	2	2.5	3	4	5	6	8	10	12
Dry	180	240	300	360	420	630	855	1185	1980	3045	4095
Lubricated	90	120	150	180	210	315	429.6	594	990	1524	2052

Crane recommends a safety factor of 1.25 be used for sizing of single valve applications

### Weight\*

	1	1.5	2	2.5	3	4	5	6	8	10	12
Water	2	4	6	8	9	11	15	17	29	44	85
Lug	N/A	N/A	8	10	11	17	21	26	42	65	108

\*Based on 255 Stainless Steel disc/stem and Cast Iron Body.

### Bolt Circle and Tapped Lug

	1	1.5	2	2.5	3	4	5	6	8	10	12
Bolt Circle	3.125	3.875	4.750	5.500	6.000	7.500	8.500	9.500	11.750	14.250	17.000
No. Holes	4	4	4	4	4	8	8	8	8	12	12
Tap	N/A		.625-11 UNC				.750-10 UNC		.875-9 UNC		

## Series 800

If you want cost-effective backflow protection for your piping systems, look at what the Series 800 from Center Line has to offer. It's the only fully elastomer-lined insert check valve available. The ductile iron valve body is completely isolated from line media which can extend the service life of the Series 800 in most applications and makes it an especially economical alternative in applications which would otherwise require check valves made of expensive alloys.

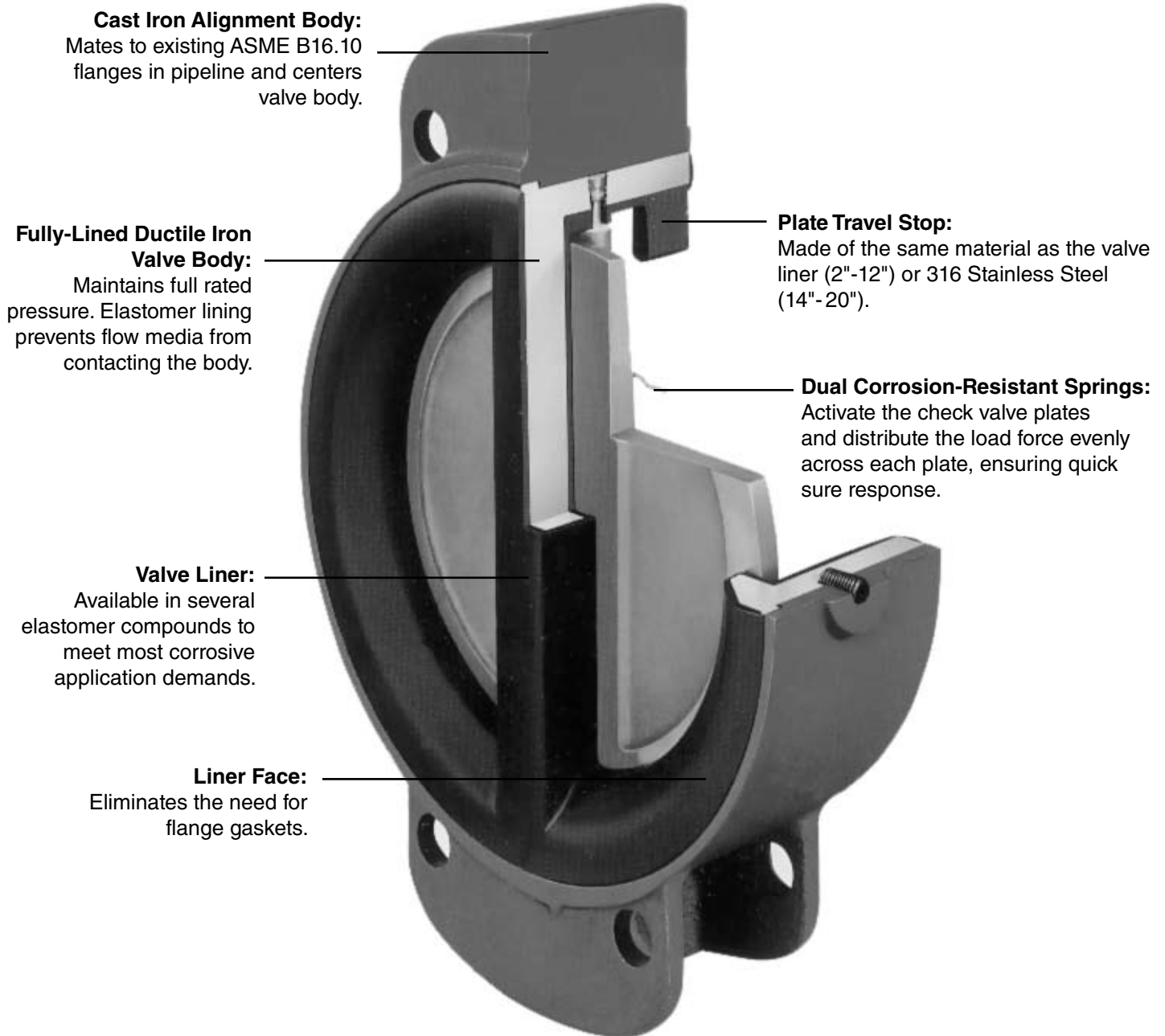

# Resilient Seated Check Valves



## Series 800

- Available in sizes 2" to 20".
- Only fully elastomer lined check valve available.
- Bubble-tight shutoff from 25 to 150 psi ΔP. Lower minimum pressure available on request.
- Wide range of available elastomers; Buna-N or EPDM standard.
- Check valves compatible with ASME B16.1, Class 125 (Iron) or B16.5, Class 150 (Steel) flanges.
- Use of dual springs distributes the load force evenly across each plate, resulting in quick response to flow reversal.
- Commercial cleaning available for Oxygen level 2.
- CE/PED Certification available for sizes 2" to 24".

### Liner Temperature Ratings

Material	Temperature Ratings °F
Buna-N (Standard)	+10 to 180
EPDM (Standard)	-30 to 275
Neoprene	+20 to 200
Viton®	+10 to 400

Some flow media may further restrict the published temperature limits and/or significantly reduce seat life. Consult factory for additional information.

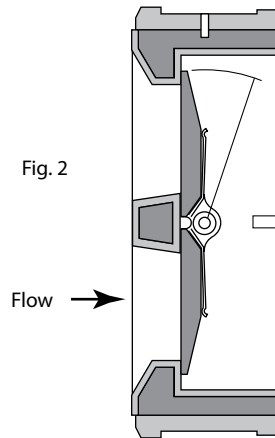
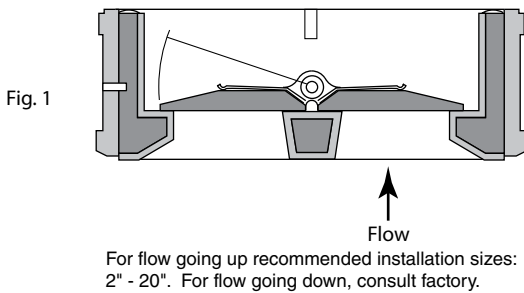

Valve should be installed with shaft in the vertical position in a horizontal pipe. This view rotated 90° for pictorial clarity.

### C<sub>v</sub> Values – Valve Sizing Coefficients (US-GPM @ 1ΔP)

Valve Size	C <sub>v</sub>	Cracking Pressure To Open Valve (Inches of Water Column)*		
		Figure 1	Figure 2	Figure 3
2"	36	14	10	5
2 ½"	62	18	12	6
3"	123	11	7	2
4"	281	10	6	2
5"	522	14	10	6
6"	1033	12	8	5
8"	2158	12	9	5
10"	3368	14	13	8
12"	5068	15	10	6
14"	6465	20	12	6
16"	9172	20	12	6
18"	12,853	16	10	–
20"	17,398	24	16	–

\*Figures are approximate. 1" of water column = .036 psi.

## Series 800

### Dimensions (in [mm]) and Weights (lbs [kg])

For installation and maintenance instructions, please refer to the IOM manual available at [www.cranvalvelit.com](http://www.cranvalvelit.com)

Valve Size	A	B	C	D	E	F	G	H	J	K	Weight
2 (50)	6.25 (158.75)	4.35 (110.49)	3.34 (84.14)	2.62 (66.68)	2.00 (51.00)	4.81 (122.17)	0.82 (20.80)	1.12 (47.63)	1.88 (47.63)	2.12 (53.98)	5 (2.27)
2 1/2 (65)	7.00 (177.80)	5.13 (130.30)	3.9 (98.43)	3.12 (79.38)	2.00 (51.00)	5.63 (143.00)	0.82 (20.80)	1.44 (36.51)	2.31 (58.74)	2.12 (53.98)	6 (2.72)
3 (80)	7.50 (190.50)	5.50 (139.70)	4.56 (115.89)	3.62 (92.08)	2.00 (51.00)	6.20 (157.48)	0.88 (22.35)	1.62 (41.28)	2.75 (69.85)	2.12 (53.98)	8 (3.63)
4 (100)	9.25 (234.95)	5.75 (146.05)	5.62 (142.88)	4.62 (117.48)	2.37 (60.19)	7.28 (184.91)	0.94 (23.87)	2.12 (53.98)	3.44 (87.31)	2.50 (63.50)	15 (6.81)
5 (125)	10.62 (269.88)	7.62 (193.68)	6.75 (171.45)	5.69 (144.46)	2.50 (63.50)	8.44 (214.37)	0.88 (22.35)	2.66 (67.47)	4.44 (112.71)	2.62 (66.68)	20 (9.08)
6 (150)	12.00 (304.80)	8.75 (222.25)	7.88 (200.03)	6.75 (171.45)	3.00 (76.20)	9.44 (239.77)	0.88 (22.35)	3.16 (80.17)	5.56 (141.29)	3.12 (79.38)	26 (11.80)
8 (200)	14.50 (368.30)	10.62 (269.88)	10.00 (254.00)	8.75 (222.25)	3.75 (95.25)	11.66 (296.16)	0.91 (23.11)	4.16 (105.57)	7.56 (192.09)	3.88 (98.43)	43 (19.52)
10 (250)	16.88 (428.63)	13.25 (336.55)	12.12 (307.98)	10.88 (276.23)	3.86 (98.04)	14.06 (357.12)	1.14 (28.95)	5.12 (130.18)	9.06 (230.19)	4.00 (101.60)	58 (26.33)
12 (300)	19.50 (495.30)	16.00 (406.40)	14.38 (365.13)	12.88 (327.03)	5.00 (127.00)	16.14 (409.95)	1.02 (25.90)	6.25 (158.75)	10.81 (274.64)	5.12 (130.18)	100 (45.40)
14 (350)	22.50 (571.50)	17.00 (431.80)	15.62 (396.88)	14.12 (358.78)	7.00 (177.80)	18.65 (473.71)	1.72 (43.68)	6.75 (171.45)	12.06 (306.39)	7.12 (180.98)	135 (61.29)
16 (400)	24.88 (631.83)	20.12 (511.18)	17.75 (450.85)	16.12 (409.58)	6.25 (158.75)	21.25 (539.75)	1.06 (26.99)	7.75 (196.85)	14.00 (355.60)	6.38 (161.93)	170 (77.18)
18 (450)	25.25 (641.35)	21.50 (546.10)	20.00 (508.00)	18.12 (460.37)	7.13 (181.10)	22.75 (577.85)	1.19 (30.16)	8.75 (222.25)	16.00 (406.14)	7.25 (184.15)	220 (99.88)
20 (500)	27.50 (698.50)	23.50 (596.90)	21.88 (555.62)	20.12 (511.17)	8.38 (212.72)	25.00 (635.00)	1.19 (30.16)	9.75 (247.65)	18.12 (469.90)	8.50 (215.90)	287 (130.30)

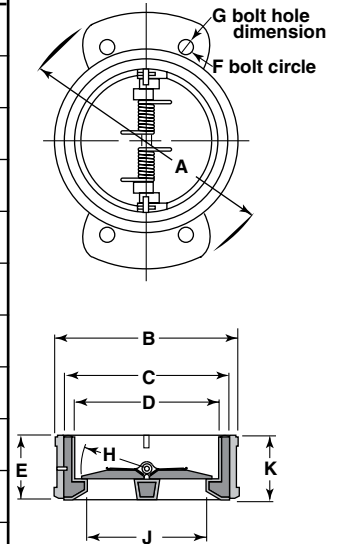

**Notes:**

Preferred mounting of check valves of any manufacturer is 8 pipe diameters downstream from the pump discharge or pipe elbow. If this is not feasible, the valve should be mounted downstream as far as possible. This recommendation is not exclusive to Center Line valves, but common practice in valve and piping engineering. Its purpose is to reduce the likelihood of turbulent flow through the valve, which could shorten valve life due to component vibration.

These dimensions reflect the universal bolting pattern valve.

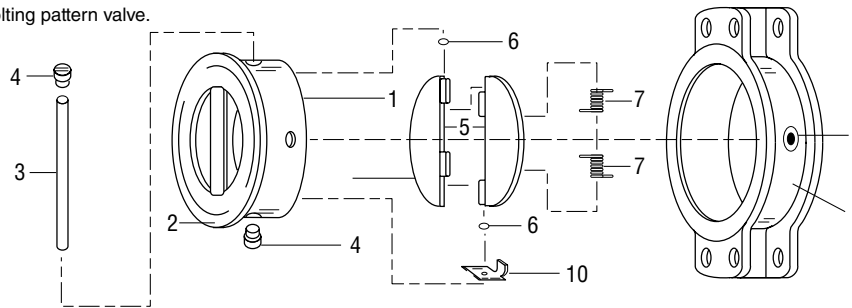

### Bill of Materials

Item	Description	Materials	Optional Materials
1*	Valve Body	Ductile Iron	No option available
2*	Liner (Molded to Item 1)	Buna-N or EPDM	Neoprene, Viton®
3	Shaft	316 Stainless Steel	Monel®
4	Shaft Plug (Qty. 2)	316 Stainless Steel	Monel®
5	Plate (Qty. 2)	2" 316 Stainless Steel 2 1/2"-5" Aluminum Bronze 6"-20" Ductile Iron	2"-12" Monel® 2 1/2"-12" 316 Stainless Steel 6"-20" Aluminum Bronze
6	Thrust Washer (Qty. 4)	PTFE	No option available
7	Spring (Qty. 2)	316 Stainless Steel	No option available
8	Alignment Body	Cast Iron	No option available
9	Set Screw	Carbon Steel	No option available
10	Plate Travel Stop	316 Stainless Steel (14"-20")	No option available

\* Items 1 and 2 must be ordered together.



# Resilient Seated Butterfly Valves



## Handles

Handles are available for on/off and throttling control of Center Line resilient seated butterfly valves. These handles can be used for manual actuation of 2" to 12" valves at 200 psi and for 2" to 6" valves at 285 psi. For valves larger than 8", excessive operator effort and extreme handle reaction to internal valve forces are possible. In these cases, a gear operator is recommended for safe operation.

### Features

The rugged construction of Center Line handles makes them ideally suited for manually actuating smaller valves. The latchplate permits the valve to be locked in any of the 10 positions on DIT handles or in any position on IOL handles.

### Specifications

- DIT Mechanically locks the valve in any of the 10 positions from 0° to 90° in 10° increments
- DIT/IOL Can hold the valve in intermediate positions (32°, 68°, etc.) and can also be locked in 0° and 90° positions



### Dimensions and Weights

Valve Size		A	B	Weight	
				DIT	DIT/IOL
2-6	in.	2.25	10.5	1.8	2.0
50-150	mm	57.15	266.7	0.8	0.9
8-12	in.	3.34	14.0	4.0	-
200-300	mm	84.84	355.6	1.8	-

Plates are adaptable for ISO or standard mounting flange.

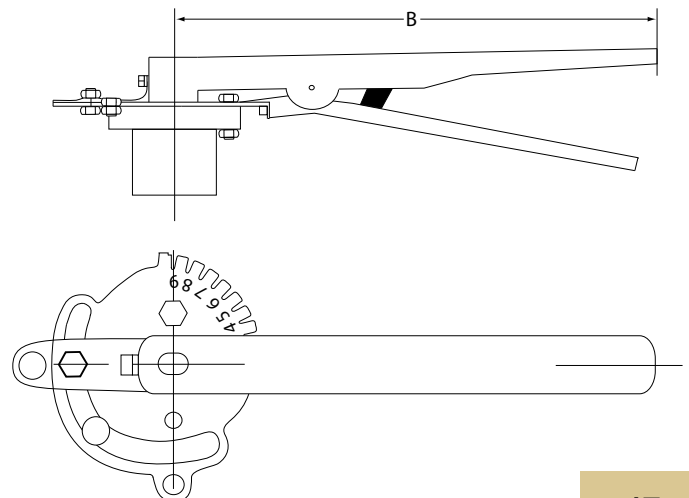
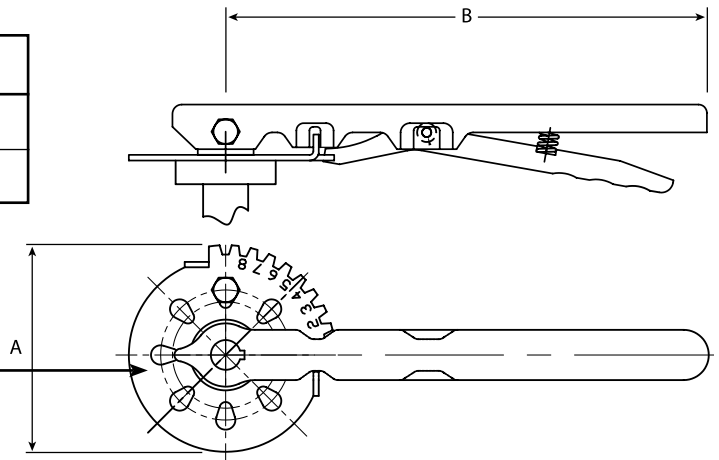

## Gear Operators

Gear operators can be used for on/off and throttling control of Center Line resilient seated butterfly valves. All models are weatherproof and usable for above ground service. Consult factory for buried service gears. For manual operation of valves, gear operators are required for valves 14" and larger and are recommended for valves 8" and larger.

### Features

Gear operators from Center Line are 90° manual actuators, and they come with a handwheel, chainwheel, or square nut input device. The durable housing completely encloses the worm gear (on the input shaft) and the segment gear (on the output). Adjustable stops are standard and factory set when installed at the factory. Fully adjustable memory stops are available as an option. A position indicator is standard on all models for above ground service.

### Specifications

**Operation** Handwheel or chainwheel or 2" square nut. Input shaft extension available.

**Mounting** Available with bolt patterns and bore/keyway for direct mount to all 2" through 30" Center Line resilient seated butterfly valves. Dual bolt patterns accommodate different pad designs. Gears are drilled for ISO pattern through 24". Contact factory for 30" and above.



## Dimensions and Weights

Valve Size (Drawing 1)	A	A1	C	E	F	G	H	Ø1	J	ØK	M	D	P	Q	Ø	ØD2	ØE	Wt. (Kg.)
2-6 in.	12.56	9.52	10.72	2.52	1.46	2.36	6.00	0.76	1.36	0.24	1.66	3.68	3.36	7.06	12.00	6.08	1.52	27.1
50-150 mm	314.00	238.00	268.00	63.00	37.00	59.00	150.00	19.00	34.00	6.00	41.50	92.00	84.00	176.50	300.00	152.00	38.00	(12.3)
8-14 in.	12.28	9.04	10.60	3.12	1.54	2.74	5.12	0.76	1.36	0.24	1.53	5.60	3.36	7.90	12.00	6.48	1.52	31.7
200-350 mm	307.00	226.00	265.00	78.00	38.50	68.50	128.00	19.00	34.00	6.00	38.20	140.00	84.00	197.50	300.00	162.00	38.00	(14.4)
16-18 in.	16.28	11.08	13.76	4.80	1.60	4.08	5.60	1.00	1.36	0.32	2.28	7.88	5.00	11.60	18.00	10.40	2.00	77.4
400-450 mm	407.00	277.00	344.00	120.00	40.00	102.00	140.00	25.00	34.00	8.00	57.00	197.00	125.00	290.00	450.00	260.00	50.00	(35.2)
Valve Size (Drawing 2)	A	B	C	D	E	F	Ø	Ø1	Ø2	Wt. (Kg.)								
20 in.	7.40	6.40	4.40	18.90	4.60	2.50	18.00	0.98	0.32	121.0								
500 mm	185.00	160.00	110.00	473.00	115.00	63.00	450.00	25.00	8.00	(55.0)								
24 in.	7.40	6.40	5.00	20.00	4.80	2.50	18.00	0.98	0.32	132.0								
600 mm	185.00	160.00	125.00	500.00	120.00	63.00	450.00	25.00	8.00	(60.0)								
28 in.	N/A	N/A	N/A	N/A	N/A	N/A	N/A	N/A	N/A	N/A								
700 mm	N/A	N/A	N/A	N/A	N/A	N/A	N/A	N/A	N/A	N/A								
30 in.	10.60	6.60	6.40	21.80	5.12	3.12	18.00	0.98	0.32	198.0								
750 mm	265.00	165.00	160.00	545.00	128.00	78.00	450.00	25.00	8.00	(90.0)								
32 in.	9.72	6.92	6.48	21.20	6.56	3.52	17.40	0.98	0.32	292.6								
800 mm	243.00	173.00	162.00	530.00	164.00	88.00	435.00	25.00	8.00	(133.0)								
36 in.	11.12	8.04	7.84	21.44	10.32	5.04	17.40	0.98	0.32	424.6								
900 mm	278.00	201.00	196.00	611.00	258.00	126.00	435.00	25.00	8.00	(193.0)								
40 in.	N/A	N/A	N/A	N/A	N/A	N/A	N/A	N/A	N/A	N/A								
1000 mm	N/A	N/A	N/A	N/A	N/A	N/A	N/A	N/A	N/A	N/A								
42 in.	16.72	10.20	9.60	25.56	12.40	5.04	17.40	0.98	0.32	792.0								
1050 mm	418.00	255.00	240.00	611.00	310.00	126.00	435.00	25.00	8.00	(360.0)								
48 in.	16.72	10.20	9.60	25.56	12.40	5.04	17.40	0.98	0.32	792.0								
1200 mm	418.00	255.00	240.00	639.00	310.00	126.00	435.00	25.00	8.00	(360.0)								

Some sizes Series 200 and 225/250 require different operators, please consult factory.

# Resilient Seated Butterfly Valves



## Gear Operators

**Drawing 1 (for sizes 2" - 18")**

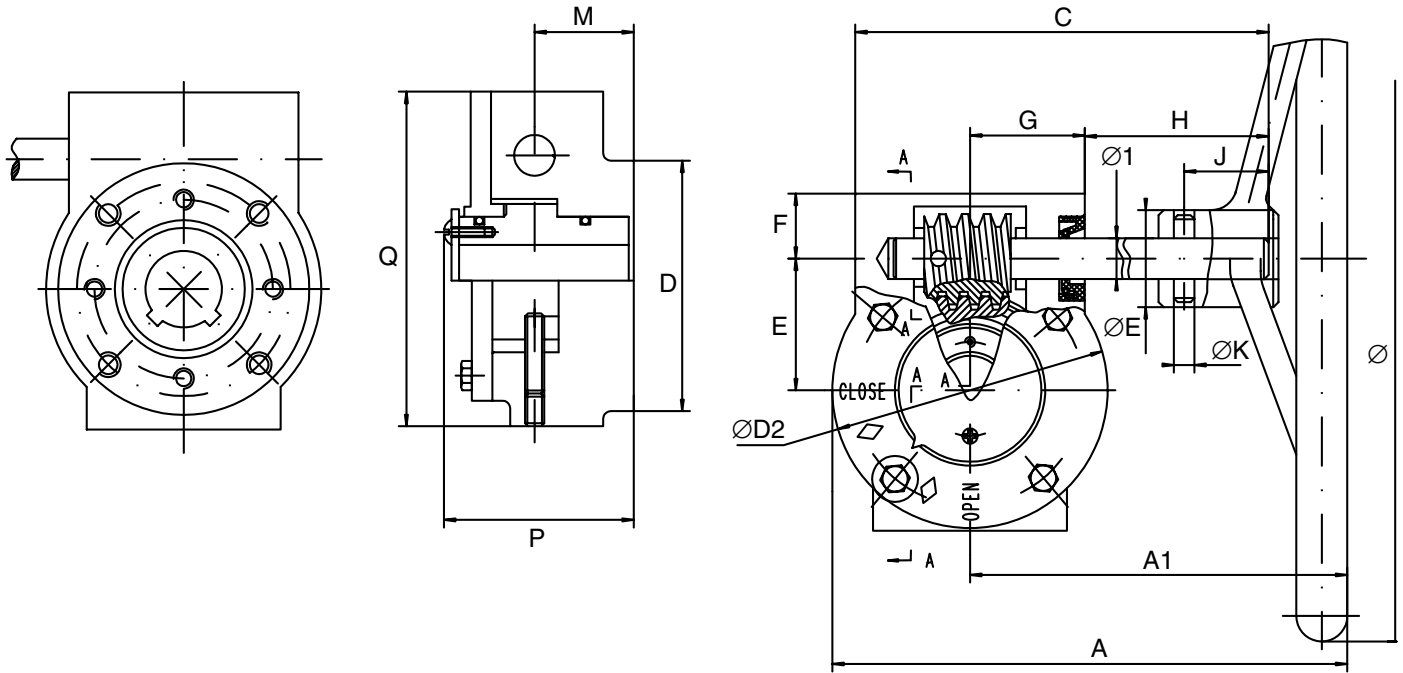

**Drawing 2 (for sizes 20" and larger)**

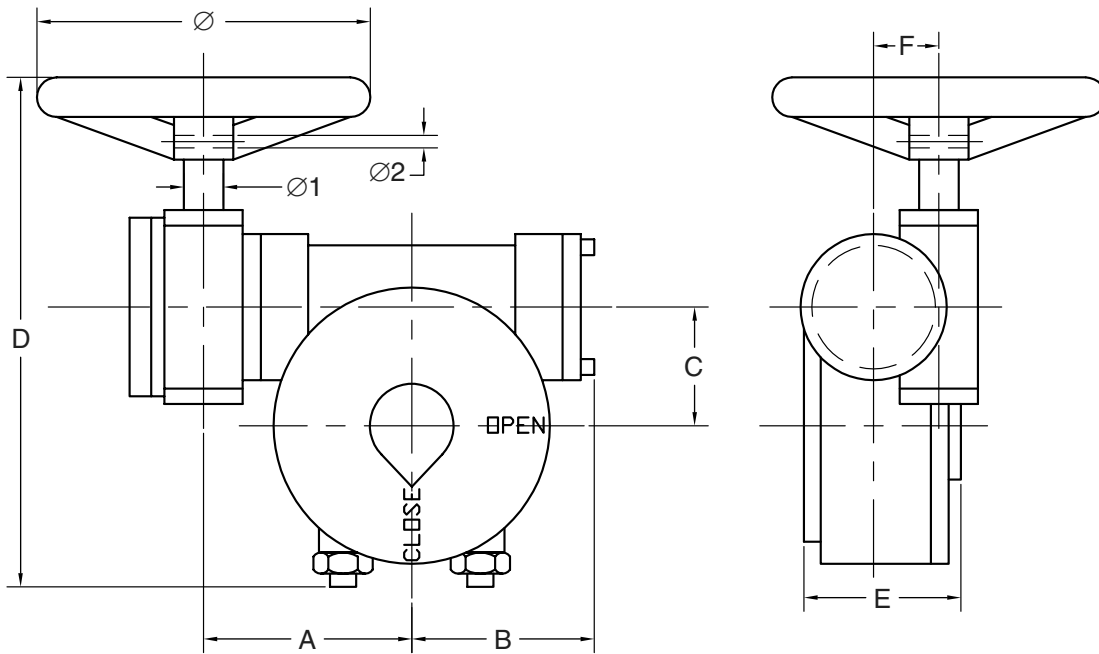

## Gear Operators

### Gear Operator Drilling Patterns

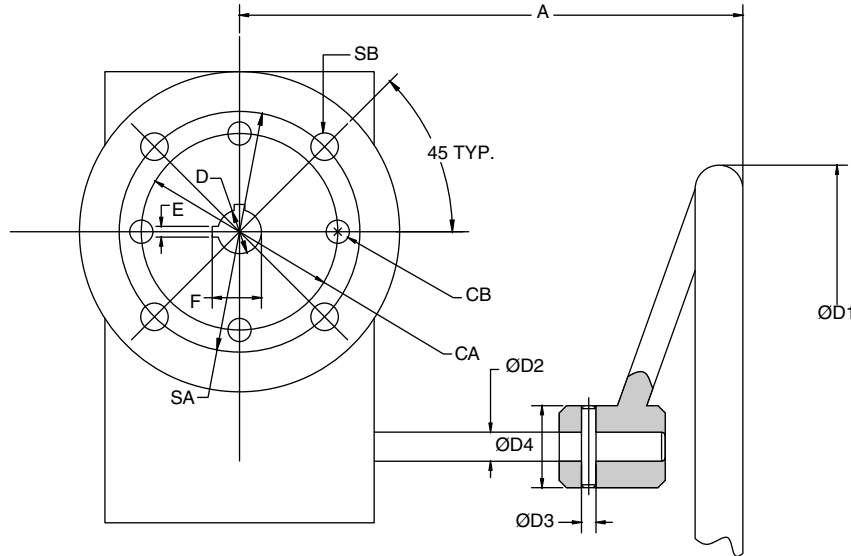

### Dimensions

Valve Size	CA	CB	SA	SB	D	ØD1	ØD2	ØD3	ØD4	A	E	F
2 in. 50 mm	2.25 57.15	M6-1	2.76 70.00	M8-15	0.50 12.70	11.81 300.00	0.75 19.00	0.24 6.00	1.50 38.00	9.37 238.00	0.13 3.18	0.56 14.30
3 in. 80 mm	2.25 57.15	M6-1	2.76 70.00	M8-15	0.50 12.70	11.81 300.00	0.75 19.00	0.24 6.00	1.50 38.00	9.37 238.00	0.13 3.18	0.56 14.30
4 in. 100 mm	2.75 69.85	M8-1.25	2.76 70.00	M8-15	0.63 15.90	11.81 300.00	0.75 19.00	0.24 6.00	1.50 38.00	9.37 238.00	0.19 4.76	0.72 18.30
5 in. 125 mm	2.75 69.85	M8-1.25	2.76 70.00	M8-15	0.75 19.05	11.81 300.00	0.75 19.00	0.24 6.00	1.50 38.00	9.37 238.00	0.19 4.76	0.84 21.40
6 in. 150 mm	2.75 69.85	M8-1.25	2.76 70.00	M8-15	0.75 19.05	11.81 300.00	0.75 19.00	0.24 6.00	1.50 38.00	9.37 238.00	0.19 4.76	0.84 21.40
8 in. 200 mm	3.50 88.90	M12-1.75	4.02 102.00	M10-18	0.87 22.20	11.81 300.00	0.75 19.00	0.24 6.00	1.50 38.00	8.89 226.00	0.19 4.76	0.97 24.50
10 in. 250 mm	3.50 88.90	M12-1.75	4.02 102.00	M10-18	1.13 28.60	11.81 300.00	0.75 19.00	0.24 6.00	1.50 38.00	8.89 226.00	0.25 6.35	1.25 31.80
12 in. 300 mm	4.25 107.95	M12-1.75	4.02 102.00	M10-18	1.25 31.80	11.81 300.00	0.75 19.00	0.24 6.00	1.50 38.00	8.89 226.00	0.25 6.35	1.39 35.00
14 in. 350 mm	4.25 107.95	M12-1.75	4.02 102.00	M10-18	1.25 31.80	11.81 300.00	0.75 19.00	0.24 6.00	1.50 38.00	8.89 226.00	0.25 6.35	1.39 35.00
16 in. 400 mm	6.25 158.75	M18-2.5	6.50 165.00	M20-26	1.31 33.30	18.00 450.00	0.98 25.00	0.32 8.00	1.99 50.00	10.90 277.00	0.31 7.90	1.49 37.30
18 in. 450 mm	6.25 158.75	M18-2.5	6.50 165.00	M20-26	1.50 38.10	18.00 450.00	0.98 25.00	0.32 8.00	1.99 50.00	10.90 277.00	0.38 9.53	1.69 42.80
18 in. 450 mm	6.25 158.75	M18-2.5	6.50 165.00	M20-26	1.63 41.30	18.00 450.00	0.98 25.00	0.32 8.00	1.99 50.00	12.64 321.00	0.38 9.53	1.81 46.00
20 in. 500 mm	6.25 158.75	M18-2.5	6.50 165.00	M20-26	1.63 41.30	18.00 450.00	0.98 25.00	0.32 8.00	1.99 50.00	12.64 321.00	0.38 9.53	1.81 46.00
24 in. 600 mm	8.50 215.90	M20-2.5	6.50 165.00	M20-26	2.00 50.80	18.00 450.00	0.98 25.00	0.32 8.00	1.99 50.00	13.19 335.00	0.50 12.70	2.24 56.80

# Resilient Seated Butterfly Valves



## Figure Number System

### Series 200



1. Size	Code
2"	02
2½"	25
3"	03
to	
48"	48

2. Series/Style	Code
Wafer (2"-30")	A
Lug (2"-30")	B
Lug/Deadend (2"-30")	C
Flange (28"-48")	D

3. Body	Code
Epoxy Coated CI (A126) (2"-12")	S
Epoxy Coated DI (A536) (2"-12")	V
Cast Iron (A126) (2"-30")	1
Ductile Iron (A536) (14"-48")	2
Ductile Iron (A395) (2"-48")	G

4. Pressure	Code
200 PSI (2"-12")	0
75 PSI Undercut	3
150 PSI (14"-48")	6
125 PSI (PTFE seat) (2"-12")	8

5. Disc	Code
Ductile Iron-ENP (2"-12")	2
316 SS	4
Ductile Iron (14"-48")	5
Aluminum Bronze (2"-48")	6
Monel® 400	7

6. Shaft	Code
416 SS	1
316 SS*	4
Monel® 400	7
17-4 PH	9

\*Standard with 316SS Disc only.

7. Bushing	Code
Bronze	0
PTFE	3

8. Seat/Liner	Code
Buna-N	1
Abrasion Resistant Buna-N	2
Black Neoprene	3
EPDM	5
Viton® (275°F)	6
Perox. Cured Buna-N	8
PTFE/Buna-N**	L
Viton® (400°F)	P
EPDM (FDA)	V
White Buna-N (FDA)	W
Potable water EPDM	D
White Buna-N	B

\*\* 2½" & 5" PTFE/Buna-N not available.

9. Actuator	Code
Handle (10 positions)	2
Infinite/Lockable (2"-6") (10 positions)	3
Infinite (8")	4
Gear Operator	5
Double Acting	6
Fail Close (SR)	7
Fail Open (SR)	8
Electric	9
Gear Operating/Balancing	G
Buried Gear/2" Nut	C
Chain Wheel	U
None	X

10. Special Features	Code
Custom Product	D
CE Marked - Non-Impact Tested	P

**NOTE:** For ASTM designations see Bill of Materials page 8.

## Figure Number System

### Series 225



1. Size	Code
2"	02
2½"	25
3"	03
to 24"	24

2. Series/Style	Code
Wafer	J
Lug	K
Lug Dead End	L
Lug ASME 300 BC	M
Lug ASME 300 DES	N

3. Body	Code
Ductile Iron (A536)	2
Epoxy Coated DI (A536)	V
Ductile Iron (A395)	G

4. Pressure	Code
200 PSI (2"-12") DES*	0
285 PSI	5
150 PSI (14"-24") DES*	6

\* Rating refers to DES without a down stream flange. For more information refer to the drawings below and the second bullet point on page 9.

5. Disc	Code
DI - ENP (2"-12")	2
316 SS	4
DI - (14"-24")	5
Aluminum Bronze	6
Monel®	7

6. Shaft	Code
416 SS	1
316 SS	4
Monel® (B865-K500 CL-A)	7
17-4 PH	9

7. Bushings	Code
PTFE	3

8. Seat/Liner	Code
Buna-N	1
Neoprene	3
EPDM	5
Viton® (275°F)	6
Viton® (400°F)	P
EPDM (FDA)	V
White Buna-N	B

9. Actuator	Code
Handle	2
Infinite/Lockable (2"-6")	3
Infinite (8")	4
Gear Operator	5
Double Acting	6
Fail Close - SR	7
Fail Open - SR	8
Electric	9
Gear Operator/Balancing	G
Buried Gear/2" Nut	D
Chain Wheel	U
None	X

10. Special Features	Code
Custom Product	D
CE Marked - Non-Impact Tested	P

NOTE: For ASTM designations see Bill of Materials page 11.

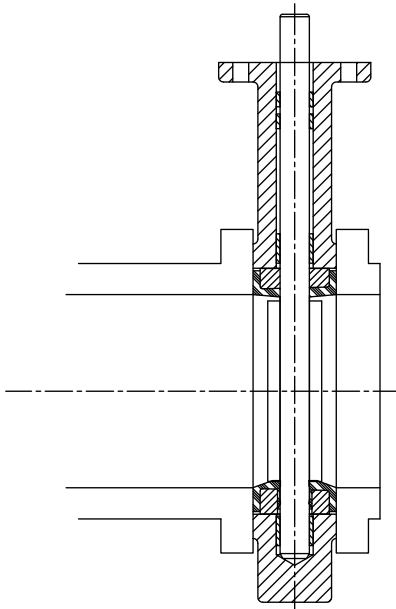

With downstream flange

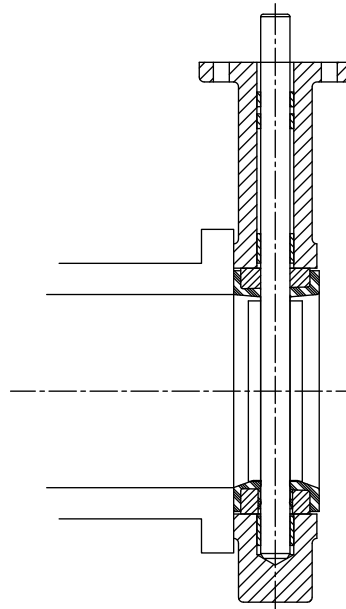

Without downstream flange

# Resilient Seated Butterfly Valves



## Figure Number System

### Series 250



1. Size	Code
2"	02
2½"	25
3"	03
to	
24"	24

2. Series/Style	Code
Wafer	2
Lug	4
Lug DES	6

3. Body	Code
Carbon Steel (non-impact)	3
316 Stainless Steel	4
Carbon Steel (impact tested)	E

4. Pressure	Code
200 PSI (2"-12") DES	0
285 PSI	5
150 PSI (14"-24") DES	6
125 PSI (2"-12") PTFE	8

5. Disc	Code
316 SS	4
Aluminum Bronze	6
Monel® 400	7

6. Shaft	Code
416 SS	1
316 SS	4
Monel® (B865-K500 CL-A)	7
17-4 PH	9

7. Bushings	Code
PTFE	3

8. Seat/Liner	Code
Buna-N	1
Neoprene (black)	3
EPDM	5
Viton® (275°F)	6
PTFE/Buna-N	L
Viton® (400°F)	P
EPDM (FDA)	V
White Buna-N (FDA)	W
White Buna-N	B

9. Actuator	Code
Handle	2
Infinite/Lockable (2"-6")	3
Infinite (8")	4
Gear Operator	5
Double Acting	6
Fail Close - SR	7
Fail Open - SR	8
Electric	9
Gear Operator/Balancing	G
Buried Gear/2" Nut	C
Direct 2" Nut	D
Chain Wheel	U
None	X

10. Special Features	Code
Custom Product	D
CE Marked - Non-Impact Tested	P
CE Marked - Impact Tested	C

**NOTE:** For ASTM designations see Bill of Materials page 11.



# Resilient Seated Butterfly Valves

## Figure Number System

### Series 700



1. Size	Code
1"	01
1½"	15
2"	02
2½"	25
3"	03
4"	04
5"	05
6"	06
8"	08
10"	10
12"	12

2. Series/Style	Code
Split Body Lug	X
Split Body Wafer	Y

3. Body	Code
Ductile Iron - A395	G
255 Duplex SS	E
Aluminum	A

4. Pressure	Code
150 PSIG	6
100 PSIG	4
50 PSIG (undercut)	9
PTFE coated-disc/stem and seat combination de-rated to 100 psig.	

5. Disc/Shaft	Code
255 Duplex SS	E
255 Duplex SS/PTFE	T
255 Duplex SS/EPDM	P
255 Duplex SS/Buna	B

6. Seat	Code
Buna-N*	2
Buna-N White*	W
EPDM	5
Viton® 400°F	P
PTFE/EPDM	M
PTFE/Buna-N	L
PTFE/Viton®	N

7. Actuator	Code
None	X
10 Pos. Handle (DI)	H
10 Pos. Handle (SS)	S
Gear Operator	O
Double Acting	6
Fall Close (SR)	7
Fall Open (SR)	8
Electric	9

\*FDA Approved and Abrasion Resistant.



# Resilient Seated Check Valves



## Figure Number System

### Series 800

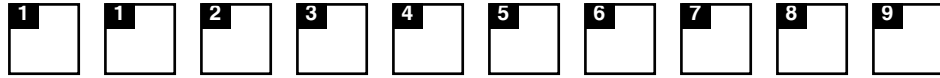

1. Size	Code
2"	02
2½"	25
3"	03
to 20"	20

2. Series/Style	Code
Wafer	R
Euro	W

3. Body	Code
Ductile Iron*	1
Epoxy Coated DI (A536)	S

\*Cast iron alignment body with a Ductile Iron fully lined valve body.

4. Pressure	Code
150 PSI	6

5. Plate	Code
316 SS (2"-14")	4
Ductile Iron (6"-20")	5
Aluminum Bronze (2.5"-20")	6
Monel® (2"-8")	7

6. Shaft	Code
316 SS	4
Monel®	7

7. Springs	Code
316 SS	D
Monel® 400	M

8. Seat/Liner	Code
Buna-N	1
Neoprene	3
EPDM	5
Viton®	0

9. Special Features	Code
CE Marked - Non-Impact Tested	P

## Actuators

### ELECTRIC – ON-OFF

**Standard Features:**

Torque Range – 347 lb ins to 17,359 lb ins  
Housing – NEMA 4 & 4X  
Electric Motor – 120 VAC, 1 PHASE, 60 Hz  
Thermal Overload – Auto re-set  
Limit Switches – Adjustable cam operated  
Position Indicator – Mechanical Dial Type  
Space Heater – Located in the control compartment  
Terminal Strip – Pre-wired for motor & limit switches  
Manual Override – Directing acting  
Brake – “Lock-cut” gear arrangement  
Adjustable Mechanical Travel Stops  
Temperature Range – -13°F to 131°F  
Mounting – Direct mount to Crane valves  
Certification/Approvals – CSA-NRTL/C

**Optional Features:**

AC Voltages – 220 VAC, 1 PHASE, 60 Hz  
AC Voltages – 24 VAC 44005 - 44400  
DC Voltages – 12/24 VDC 4005 - 44300  
Additional Limit Switches – 2 SPDT  
Torque Switches – Adjustable open and close  
Feedback Potentiometer – 500 ohm  
Feedback Transmitter – 4-20 mA  
De-clutchable Handwheel Override



### ELECTRIC – MODULATING

**Standard Features:**

Process Control Signal – 4-20 mA, 0-10 VDC  
Torque Range – 347 lb ins to 17,359 lb ins  
Housing – NEMA 4 & 4X  
Electric Motor – 120 VAC, 1 PHASE, 60 Hz  
Thermal Overload – Auto re-set  
Resolution – 400 increments through 90 degrees  
Position Indicator – Mechanical Dial Type  
Space Heater – Located in the control compartment  
Terminal Strip – Pre-wired for motor & limit switches  
Manual Override – Directing acting  
Brake – “Lock-cut” gear arrangement  
Adjustable Mechanical Travel Stops  
Temperature Range – -13°F to 131°F  
Mounting – Direct mount to Crane valves  
Certification/Approvals – CSA-NRTL/C

**Optional Features:**

AC Voltages – 220 VAC, 1 PHASE, 60 Hz  
AC Voltages – 24 VAC 44010M - 44200M  
Torque Switches – Adjustable open and close  
De-clutchable Handwheel Override

## Actuators

### PNEUMATIC – DOUBLE ACTING

#### Standard Features:

Torque Range – 62 in-lbs to 47,250 in-lbs  
Housing – Extruded aluminum, ASTM B210 (6063)  
Mounting – DIN ISO 5211, direct mounting to Center Line butterfly valves  
Position Indicator – NAMUR standard  
Operating Pressure – 40 to 150 PSIG  
Temperature Range – -10°F (-23°C) to 176°F (80°C)  
Size Range – 15 models to choose from  
Adjustable Travel Stops – Both directions  
Accessory Interfaces – VDI/VDE 3845 (NAMUR) standard

#### Optional Features:

Temperature Range – 10°F to 250°F, -55°F to 176°F  
Solenoid Valves – 3 or 4 way  
Limit Switches – Adjustable cam operated  
Positioners – Pneumatic or Electro-pneumatic  
Manual Override – De-clutchable gear type  
Speed Controls – Adjust cycle time  
Special Applications – Water, Nitrogen, and compatible hydraulic fluids may be used to operate

### PNEUMATIC – SPRING RETURN

#### Standard Features:

Torque Range – 40 in-lbs to 45,466 in-lbs  
Housing – Extruded aluminum, ASTM B210 (6063)  
Mounting – DIN ISO 5211, direct mounting to Center Line butterfly valves  
Position Indicator – NAMUR standard  
Operating Pressure – 40 to 150 PSIG  
Temperature Range – -10°F (-23°C) to 176°F (80°C)  
Size Range – 15 models to choose from  
Adjustable Travel Stops – Both directions  
Accessory Interfaces – VDI/VDE 3845 (NAMUR) standard

#### Optional Features:

Temperature Range – 410°F to 250°F, -55°F to 176°F  
Solenoid Valves – 3 or 4 way  
Limit Switches – Adjustable cam operated  
Positioners – Pneumatic or Electro-pneumatic  
Manual Override – De-clutchable gear type  
Speed Controls – Adjust cycle time  
Special Applications – Water, Nitrogen, and compatible hydraulic fluids may be used to operate



**CRANE** *Air*

## Technical Data

The nomograph on the next page gives the relationships of valve size, flow, velocity, and pressure drop for various disc positions.

### Sample Calculation, Liquid (see black line on chart)

#### Given:

Water (1.0 specific gravity) at 60°F is flowing through a 6-inch valve at a rate of 1000 gpm.

#### Find:

Line velocity (ft./sec.) and pressure drop when valve is in full-open (disc at 90°) position.

#### Solution:

From the 6-inch valve size at lower left of nomograph, go diagonally up to the intersecting horizontal line for 1000 gpm. From that point, proceed directly down to determine line velocity as 11 ft./sec.

For pressure drop, return to the 1000 gpm intersection and continue up vertically to "90° disc open" intersecting diagonal line. From this point, go horizontally to the left to determine pressure drop as 0.5 psi.

### Sample Calculation, Gas (see gold line on chart)

#### Given:

Gas (0.8 lb/cu. ft. density) is flowing through an 8-inch valve at a rate of 1500 cu. ft./min.

#### Find:

Line velocity (ft./min.) and pressure drop when valve is in full-open (disc at 90°) position.

#### Solution:

From 8-inch valve size at lower left of nomograph, go diagonally up to the intersecting horizontal line for 1500 cu. ft./min. From that point, proceed directly down to the bottom line of the nomograph to determine line velocity as 4000 ft./min.

For pressure drop, return to the 1500 cu. ft./min. intersection and continue up vertically to "90° disc open" intersecting diagonal line. From this point, go horizontally to the left to determine pressure drop as 17 psi. Now, convert pressure drop to gas by dividing gas density by liquid density and multiplying by 17.

### General Notes

- Liquid flow data is based on pressure drop and flow rate with viscosity similar to water at 60°F using flow coefficient.

$$\frac{0.8}{62.34} \times 17.0 = 0.22 \text{ psi}$$

- Velocities for liquids with densities similar to water should be less than 16 ft./sec.
- Nomograph flow rate for gases is in cubic feet per minute (CFM) at flowing conditions. To convert flow rate from standard cubic feet per minute to CFM, use the following formula:
- Gas density in lbs./cu. ft. equals:

$$\text{CFM} = \frac{(\text{SCFM} \times 14.7) \times (460 + ^\circ\text{F})}{(\text{line pressure, psia}) \times 520}$$

$$\left( \frac{270 \times}{\text{line pressure, psia}} \right) \times \left( \frac{\text{specific gravity of gas (relative to air)}}{460 + ^\circ\text{F}} \right)$$

Size	C <sub>v</sub> at Full-Open
2"	115
2 1/2"	196
3"	302
4"	600
5"	1022
6"	1579
8"	3136
10"	5340
12"	8250
14"	11917
16"	16388
18"	21705
20"	27908
24"	43116
30"	73426

### Definitions

**C<sub>v</sub>** = Flow coefficient for valves; expresses flow rate in gallons per minute of 60°F water with 1.0 psi pressure drop across valve.

**K** = resistance coefficient.

$$K = d \sqrt{\frac{29.9}{C_v}}$$

**P** = weight density of fluid, in pounds per cubic foot.

**d** = internal diameter of Schedule 40 pipe, in inches.

**Q** = rate of flow, in gallons per minute.

**ΔP** = differential pressure, in pounds per square inch gauge.

# Resilient Seated Butterfly Valves



## Technical Data

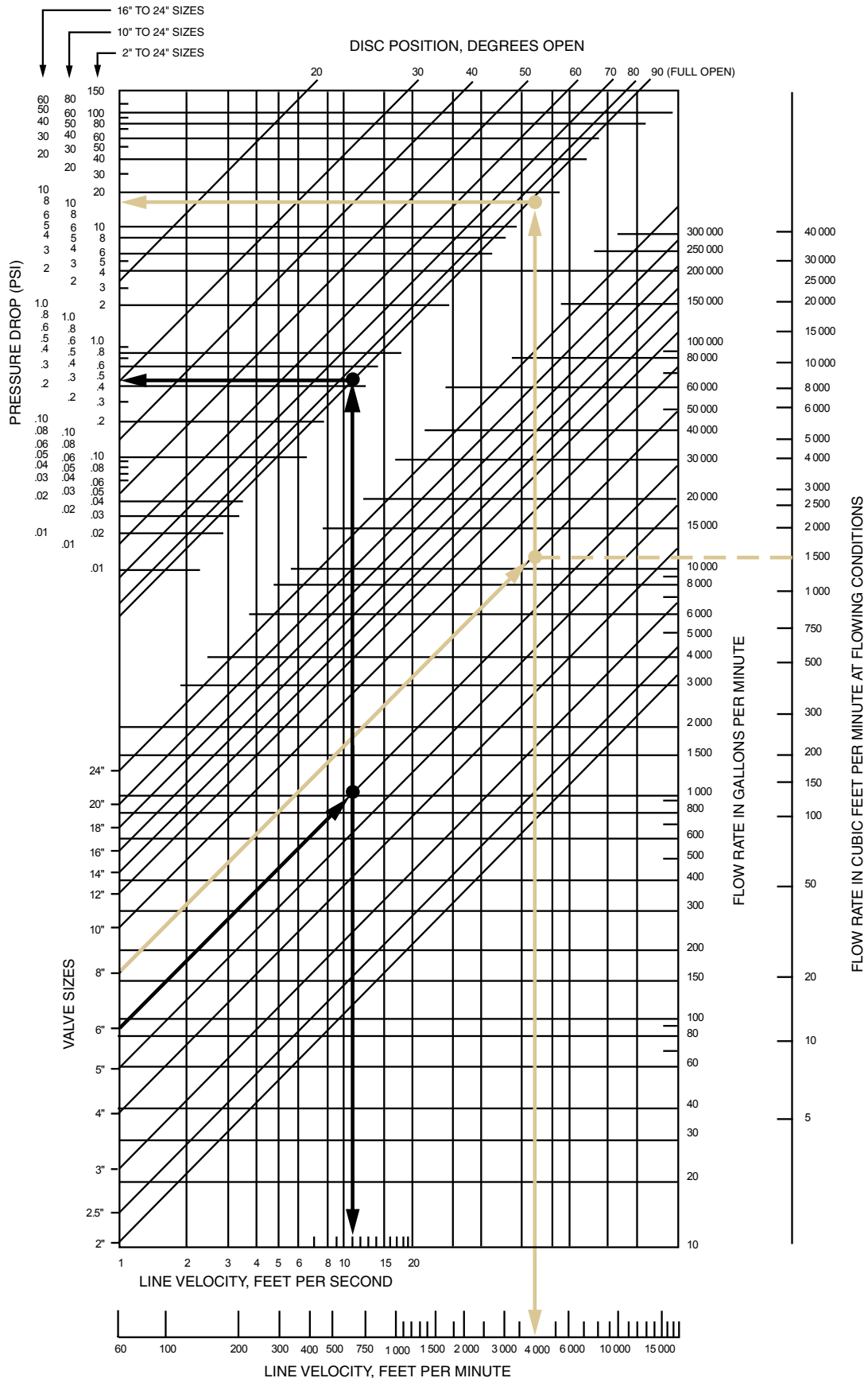



# Resilient Seated Butterfly Valves

## Technical Data

### Seat Temperature Ratings & Application Information

Elastomer	Continuous Temp Range	Description
Buna-N	+10°F to 180°F	<p>Also known as Nitrile or NBR. Buna-N is a good, general purpose material for most general services such as water at ambient temperatures, vacuum, compressed air, salt solutions, alkaline solutions and aliphatic h hydrocarbons (saturated and unsaturated).</p> <p><b>Buna-N is not recommended for strong oxidizing agents, nitrated hydrocarbons, Ketones, acetates, phenols, aldehydes or for gasolines with additives. Also, Buna-N can swell in hot water applications, and increase operating torque.</b></p>
EPDM	-30°F to 275°F	<p>EPDM is a synthetic rubber suitable for many general purpose applications with higher temperature requirements. It is acceptable for hot and chilled water, glycols, detergents, phosphate esters, Ketones and alcohols.</p> <p><b>EPDM is not suitable for any hydrocarbon-based oils and lubricants, or in compressed air systems with hydrocarbons.</b></p>
Viton®	+10°F to 400°F	<p>Viton® is a fluoroelastomer with exceptional resistance to oils and chemicals at higher temperatures. Viton® is suitable for hydrocarbons, and has a greater chemical resistance than Buna-N. Viton® can also be recommended for mineral acids, dilute and concentrated solutions and alcohols.</p> <p><b>Viton® is not recommended for higher temperature water and steam applications as it has a tendency to swell. Also, Viton® hardens at the lower end of the temperature range, which can increase operation torque.</b></p>

Crane is please to offer other seat materials upon request. Please consult your sales representative or the factory for availability and application information.

### Notes

---

---

---

---

---

---

---

---

---

---

---

---

---

---

---

---

---

---

---

---

---

---

---

---

---



# CRANE<sup>®</sup>

## Energy Flow Solutions

### CRANE Energy Global Headquarters

19241 David Memorial Drive, Suite 150  
Shenandoah, Texas 77385  
Tel: +1-936-271-6500  
Fax: +1-936-271-6510



### Sydney, Australia Operations

146-154 Dunheved Circuit  
St. Mary's, N.S.W. 2760  
Sydney, Australia  
Tel: +61-29-623-0234  
Fax: +61-29-673-3870

### Conroe, Texas Operations

9860 Johnson Road  
Montgomery, Texas 77316  
Tel: +1-936-588-8380  
Fax: +1-936-588-8381

### Ningjin, China Operations

No. 8 Youyi Street Ningjin County  
Hebei Province, China 055550  
Tel: +86-319-580-6651  
Fax: +86-319-580-8661

[www.craneenergy.com](http://www.craneenergy.com)

## CRANE Energy Flow Solutions<sup>®</sup>

brands you know...technology you want...solutions you need



Ball, Check, Corrosion Resistant Gate and Globe Valves



**KROMBACH**  
ARMATUREN

Valve System Solutions, Highly Engineered Specialty Valves



Lined Check and Resilient Seated Butterfly Valves

**NOZ-CHEK<sup>®</sup> COMPAC-NOZ<sup>®</sup>**

Nozzle-Type, Severe Service Check Valves

**CRANE**

Ball, Bronze, Butterfly, Cast Steel, and Iron Valves



High Pressure and Severe Service Valves

**DUO-CHEK<sup>®</sup> UNI-CHEK<sup>®</sup>**

High Performance Wafer Check Valves

**STOCKHAM<sup>®</sup>**

Ball, Bronze, Butterfly, Cast Steel, and Iron Valves



High Performance Butterfly and Metal Seated Valves



Cast Steel Valves



Ball, Bronze, Butterfly, Cast Steel, and Iron Valves

**VALVE SERVICES**

Certified Valve Repair Services

Aloyco, Center Line, Compac-Noz, Crane, Duo-Chek, Flowseal, Jenkins, Krombach, Noz-Chek, Pacific, Stockham, Triangle, and Uni-Chek are all trademarks of Crane Co. ©2010

EG-CL-CT-EN-L11-05-1007 (CV-10)